

PRICELIST

WE ARE COUNTING ON YOU

2026



>>



gewista

Table of contents

Premium Board	5
Billboard	9
City Light	13
City Light Column	17
Digital Media	21
Premium Screen	27
Retail Advertising	31
Tram & Bus Advertising	35
Underground Advertising & Brand Area	41
Permanent Advertising	47
Mobile Advertising	53
Megaboard	55
Infoscreen	57
Kulturformat	59
Out of Home International	61
Gewista Team	63
Posting Calendar	64
General terms and conditions	66

Subject to errors and misprints



Premium Board

The premium board combines all the elements you've always wanted from outdoor advertising!

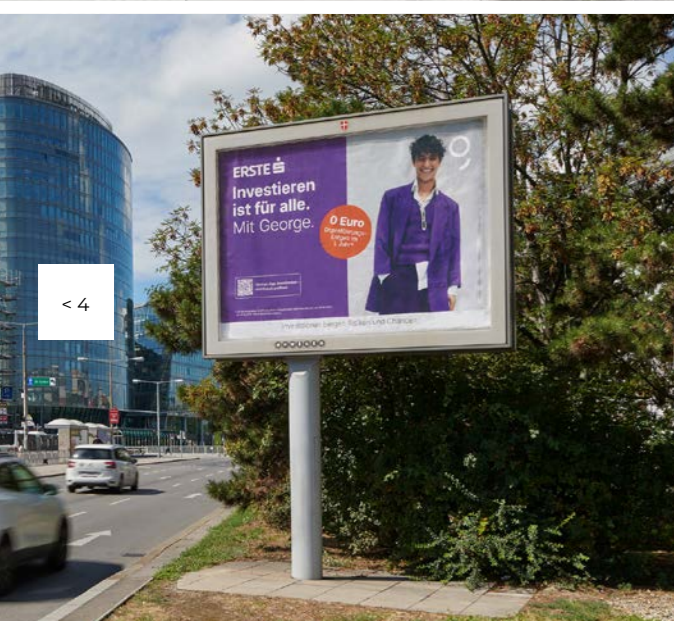

- Exclusive presence, only one customer per location.
- At right angles to the road.
- High-frequency locations with long dwell times.
- Hovering at a height of 2.6 to 3.5 metres above the traffic, no disruptive elements.
- Backlit and backglazed, thus protected from weather and vandalism.

PREMIUM BOARD

Minimum rental period 7 days
 Prices in Euro | All prices exclude taxes and VAT

Region	Piece	Amount in €*
NATIONAL incl. Vienna large	315	88.684,62
NATIONAL incl. Vienna medium	244	70.648,54
NATIONAL incl. Vienna small	204	60.561,17
NATIONAL excl. Vienna	126	39.588,29
VIENNA large	189	50.782,32
VIENNA medium	118	32.727,24
VIENNA small	78	22.489,88
EAST REGION (Lower Austria + Burgenland)	58	18.794,12
CARINTHIA	16	5.481,69
STYRIA	24	8.093,53
UPPER AUSTRIA	14	4.832,48
SALZBURG, TYROL + VORARLBERG	14	4.832,48

*Budget basis: rent & assembly before agency fee

EXPLANATION OF TERMS

Format
 Visible area 300 x 216 cm
 Overall format incl. passepartout 314 x 231 cm

Special advertising formats on request.

Delivery of the finished advertising material
 no later than 10 working days before the start of the campaign, including a 10% over delivery.

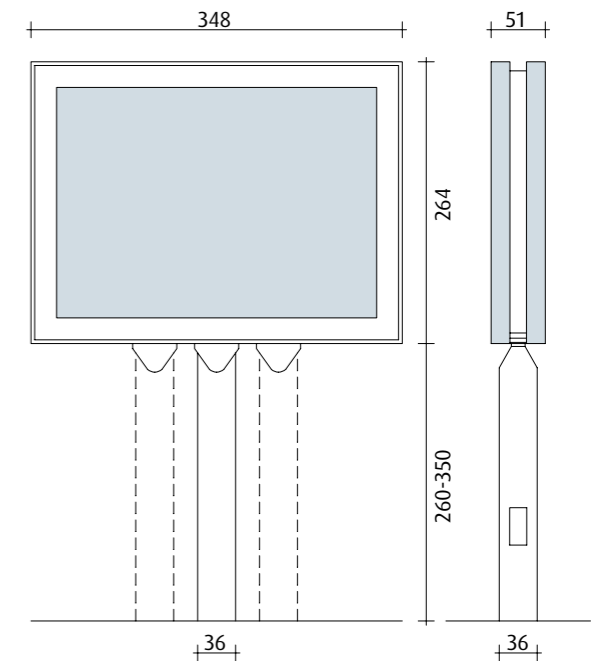

Billboard

Especially in the digital era, billboard advertising impresses with its impact, quality and durability. It is also the preferred medium to build up national, regional or local awareness.



The billboard formats are as varied as the customers' needs: We offer formats from 8-, to 48-sheets and support our clients with innovative design options if required.

16,000
billboards
throughout
Austria.

BILLBOARDS

Minimum rental period 14 days
Prices in Euro | All prices exclude taxes and VAT

RENT per 1.000 contacts	MAIN CITY REGION (MCR)	8 SHEETS Per area	16 SHEETS		24 SHEETS		48 SHEETS	
			BASIS-TKP	SELECT-TKP	BASIS-TKP	SELECT-TKP	BASIS-TKP	SELECT-TKP
EAST	Vienna	37,70	3,50	4,90	4,60	6,45	9,20	12,10
	Greater Vienna area							
	Sankt Pölten Lower Austria							
CENTRAL AUSTRIA	Graz	37,70	4,10	5,20	5,40	6,70	10,80	13,40
	Styria							
	Klagenfurt/Villach							
	Carinthia Central Upper Austria Upper Austria							
WEST	Salzburg	37,70	4,85	5,60	6,15	7,10	12,30	14,20
	Greater Salzburg area							
	Innsbruck							
	Tyrol area Vorarlberg							
Assembly	per area	24,25	40,12	57,93	115,86			
Replacement costs (separate change of subject)	per area	38,80	64,19	92,69	185,38			



EXPLANATION OF TERMS

Basis

Booking of contacts or spaces in an OSA region without specification by the customer (price basis in the OSA analysis tool).

Selection (Select)

Booking of contacts or spaces in an OSA region defined by the customer (cities, districts, streets...).

Special advertising formats upon request.

Delivery of the finished advertising material

no later than 10 working days before the start of the campaign, including a 15% over delivery.

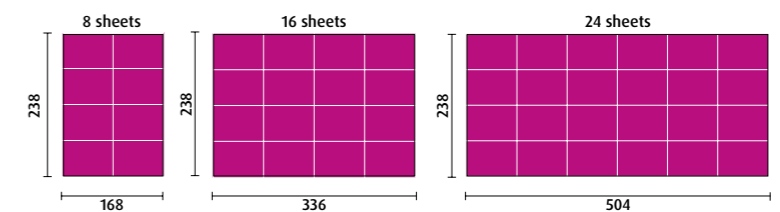
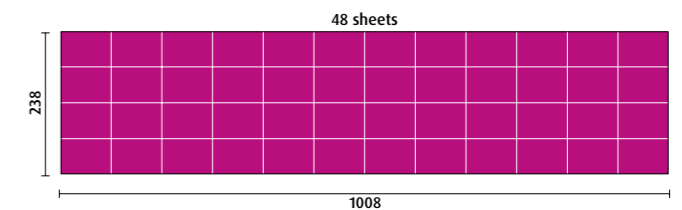

City Light

The possible uses of our City Lights are almost unlimited. Especially during waiting times in our tram shelters, inspiring subjects are providing a welcome distraction.



Our City Lights offer targeted and geo-selected locations 24 hours per day and 7 days per week. City Lights ensure high recall, recognition and high reach for your advertising campaign.

More than 8.000 panels to choose from.

CITY LIGHT

Minimum rental period 7 days
Prices in Euro | All prices exclude taxes and VAT

City Light*	Regional	Selection	National	Vienna city centre
EAST	4,57 except 1010	5,95	4,48 except 1010	5,50
CENTER	5,30	5,95	4,48	-
WEST	5,30	5,95	4,48	-
Surcharge from 5.11.2026	6,10	6,84	5,15	6,33
Assembly	15,30			
Replacement	24,48			

* EXPLANATION CITY LIGHT PRICING

Regional	less than 3 provinces	Vienna: TKP 4,57 / all others: TKP 5,30
Region East	Vienna and/or Lower Austria	W, WU, St.P., NÖ: TKP 4,57
Selection	Point of Interest / Point of Sales	
National	with at least 3 provinces	e.g., the entire east (counted as one province) as well as Styria+Salzburg or Vienna, Styria, Salzburg



EXPLANATION OF TERMS

National

From three booked provinces, the booking is considered national; Ex.: Vienna + Linz + Graz. or Salzburg + Upper Austria + Styria.

Local (Select)

Booking of contacts or spaces in an OSA region defined by the customer (cities, districts, streets,...).

Season surcharge

From November 5th to December 23rd, 2026, a surcharge of 15% will be applied to the rental costs.

Format

Paper size: 118,5 x 175 cm
Unrestricted visibility 103,8 x 161,5 cm (portrait format)

Paper: 150 g, white, matt, wood-free, translucent

Delivery of the finished advertising material

no later than 10 working days before the start of the campaign, including a 15% over delivery.

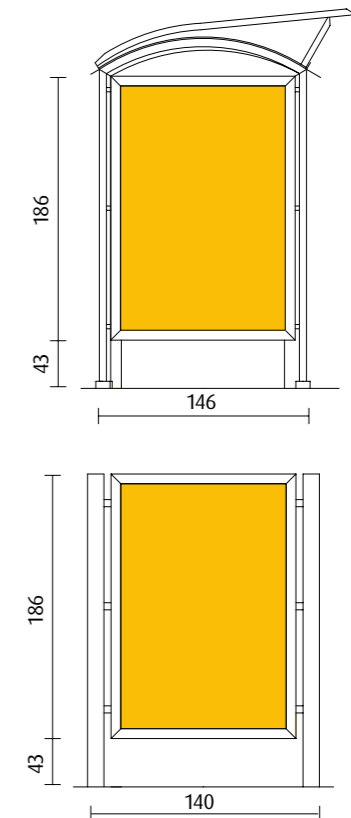

City Light columns

Another highlight are our back-lit revolving advertising columns, which guarantee aesthetics and attention in the Viennese downtown area.



< 16

17 >

The City Light columns are not only a popular anchor point for nostalgia lovers in a constantly changing world. They are also an established advertising media in the OOH sector.

Attract attention in busy urban places.

CITY LIGHT COLUMNS

Minimum rental period 7 days | Minimum booking of two City Light formats per column
 Prices in Euro | All prices exclude taxes and VAT

City Light*	Regional	Selection	National	Vienna city centre
EAST	4,57 except 1010	5,95	4,48 except 1010	5,50
CENTER	5,30	5,95	4,48	-
WEST	5,30	5,95	4,48	-
Surcharge from 5.11.2026	6,10	6,84	5,15	6,33
Assembly	15,30			
Replacement	24,48			

*** EXPLANATION CITY LIGHT PRICING**

Regional	less than 3 provinces	Vienna: TKP 4,57 / all others: TKP 5,30
Region East	Vienna and/or Lower Austria	W, WU, St.P, NÖ: TKP 4,57
Selection	Point of Interest / Point of Sales	
National	with at least 3 provinces	e.g., the entire east (counted as one province) as well as Styria+Salzburg or Vienna, Styria, Salzburg

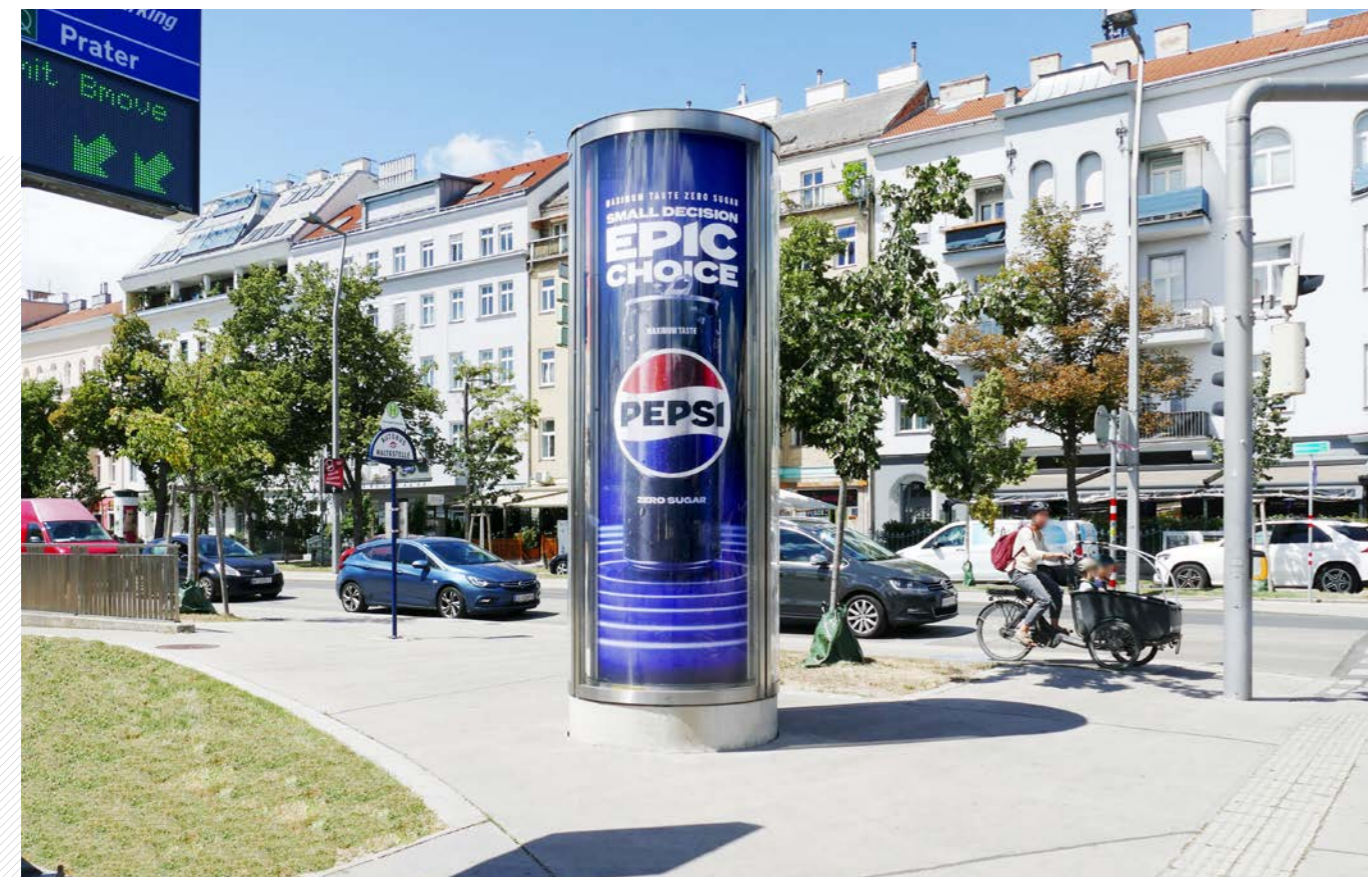

EXPLANATION OF TERMS

National

From three booked provinces, the booking is considered national; Ex.: Vienna + Linz + Graz. or Salzburg + Upper Austria + Styria.

Local (Select)

Booking of contacts or spaces in an OSA region defined by the customer (cities, districts, streets,...).

Season surcharge

From November 5th to December 23rd, 2026, a surcharge of 15% will be applied to the rental costs.

Delivery of the finished advertising material

no later than 10 working days before the start of the campaign, including a 15% over delivery.

The City Light column can be equipped with two individual sujets or one column sujet.

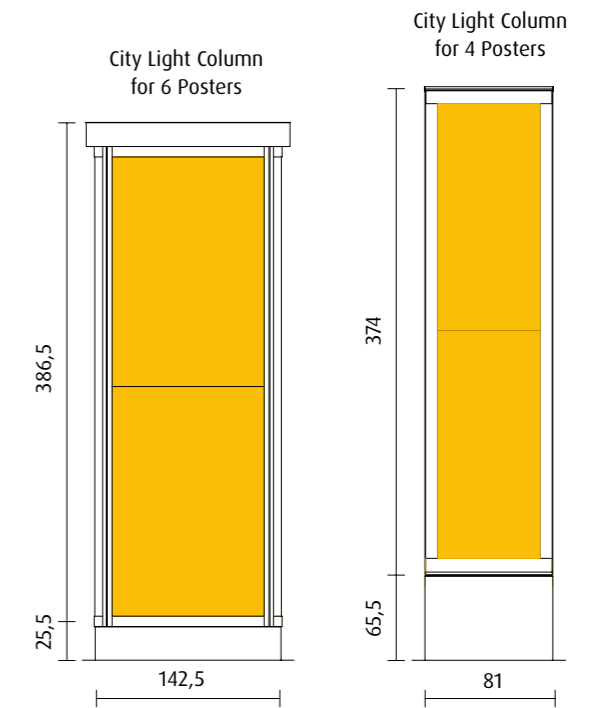

Production information for CL Column subject.*

Format

Paper size in total
118,5 x 352 cm

unrestricted visibility
118,5 x 342 cm
(portrait format)

Paper CL Poster upper area
118,5 x 176 cm
(in one piece)

Paper CL Poster lower area
118,5 x 178 cm
(in one piece)

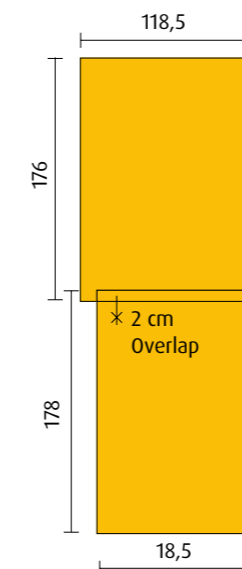

* 2 x 2 mounted on top of each other. The lower CL Poster is 2 cm higher to overlap the upper CL Poster by 2 cm.



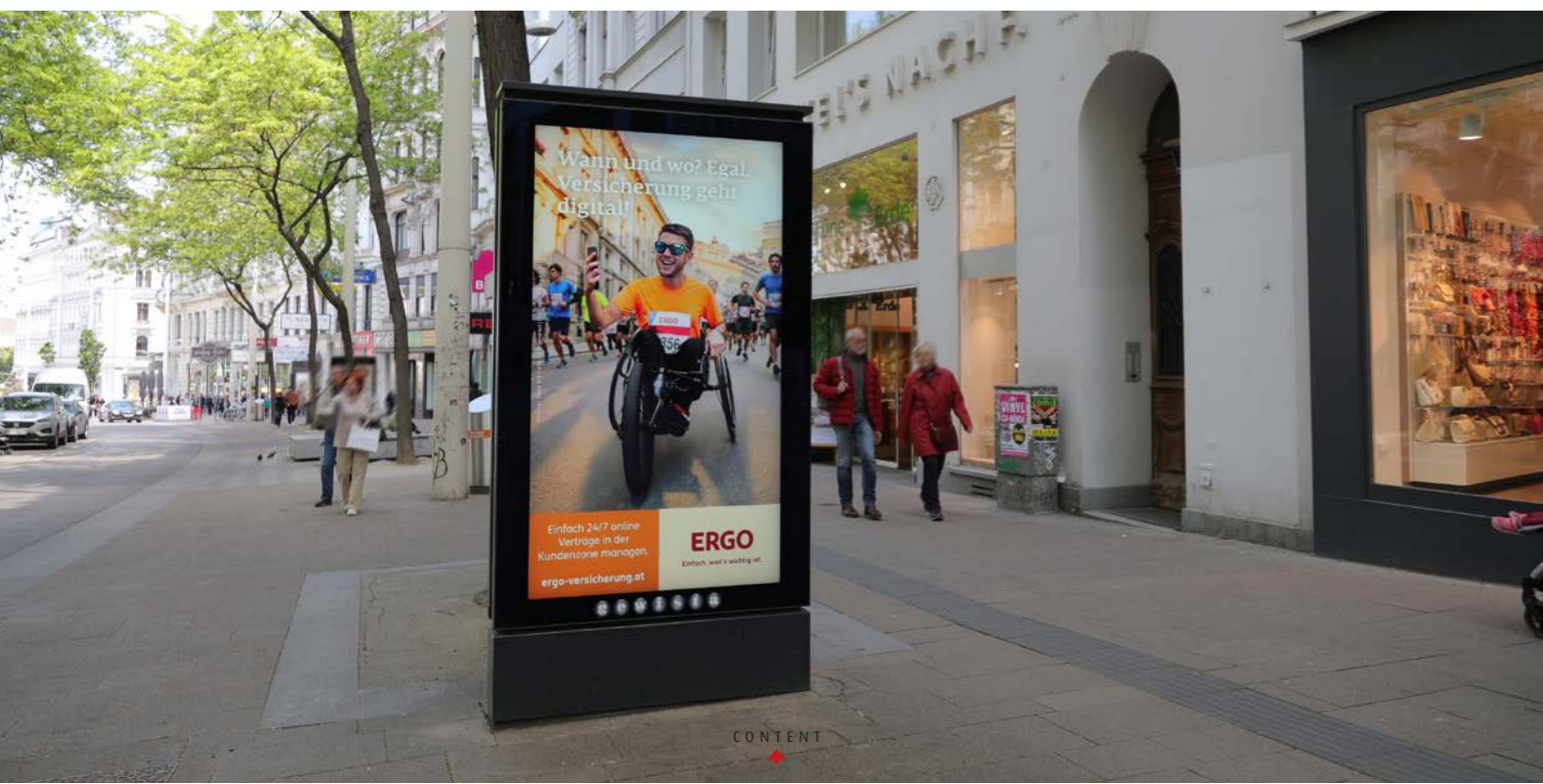
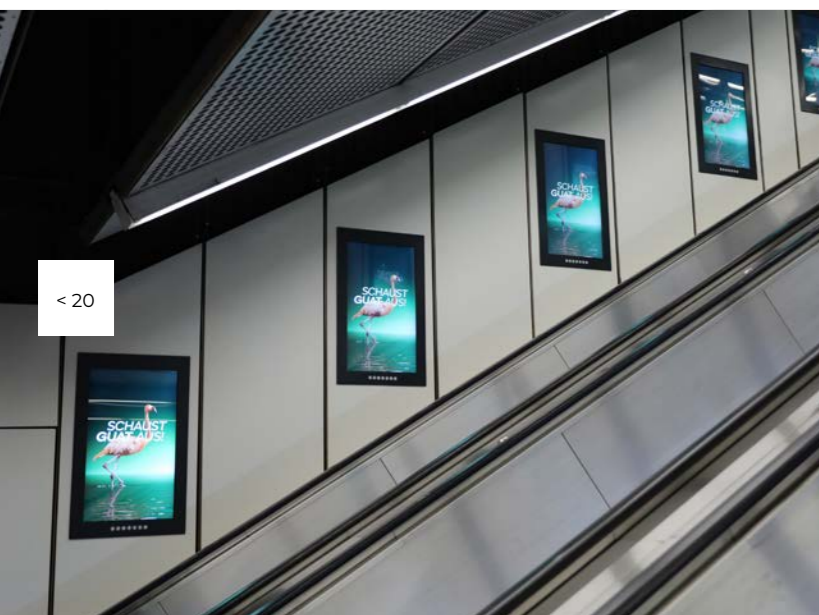

Digital Media

The digital City Lights create unique and dynamic product landscapes for innovative advertising campaigns in urban spaces and busy underground stations, inner city hotspots and premium locations. DOOH by Gewista presents your brand in Vienna and in most of the other provincial capitals in Austria.

As an attractive advertising medium with a wide range of applications, it is the growth driver in the advertising market. Interactive outdoor advertising not only boosts response rates among the target audience, but also increases awareness and brand recall through the use of Smart Content. Our networks provide you with reach optimization, customised to your specific needs.

The ideal presentation option for visual, digitised content in public spaces.

DIGITAL MEDIA - TRANSPORT

Duration 7 days

Prices in Euro | All prices exclude taxes and VAT

Frame Groups		80" DCL	32" DCL	HD-Videowall	TKP
Stephansplatz	Escalator 4 und 8	-	36 Units	-	5,90
	Escalator 7 und 9	-	42 Units	-	5,90
	Stephansplatz 1	12 Units	-	-	5,90
	Stephansplatz 2	13 Units	-	-	5,90
	Stephansplatz 3	6 Units	-	-	5,90
Westbahnhof	Westbahnhof 1	9 Units	-	-	5,90
	Westbahnhof 2	9 Units	-	-	5,90
	Westbahnhof 3	6 Units	-	-	5,90
	Escalator 11	-	16 Units	-	5,90
Wien Mitte	Landstraße 1	7 Units	-	-	5,90
	Landstraße 2	3 Units	-	-	5,90
	The Mall	5 Units	-	-	5,90
Karlsplatz	Escalator 7	1 Units	44 Units	-	5,90
	Escalator 13	1 Units	28 Units	-	5,90
	Videowalls	-	-	2 Units	5,90
Praterstern	Praterstern 1	5 Units	-	-	5,90
	Praterstern 2	5 Units	-	-	5,90
	Praterstern 3	5 Units	-	-	5,90
	Praterstern 4	10 Units	-	-	5,90
	Praterstern 5	4 Units	-	-	5,90
Schwedenplatz	Escalator 1	-	24 Units	-	5,90
	Escalator 2	-	24 Units	-	5,90
	Escalator 3	-	16 Units	-	5,90
	Escalator 4	-	16 Units	-	5,90
	Escalator 5	-	16 Units	-	5,90
	Schwedenplatz 1	8 Units	-	-	5,90
	Schwedenplatz 2	3 Units	-	-	5,90
Volkstheater	Volkstheater 1	7 Units	-	-	5,90
	Volkstheater 2	7 Units	-	-	5,90
City Netz Metro	City Netz Metro 1	23 Units	-	-	5,90
	City Netz Metro 2	22 Units	-	-	5,90

Handling Fee €515 will be charged 1x per province and up to 3 spots. Data processing and adaptation: costs on demand

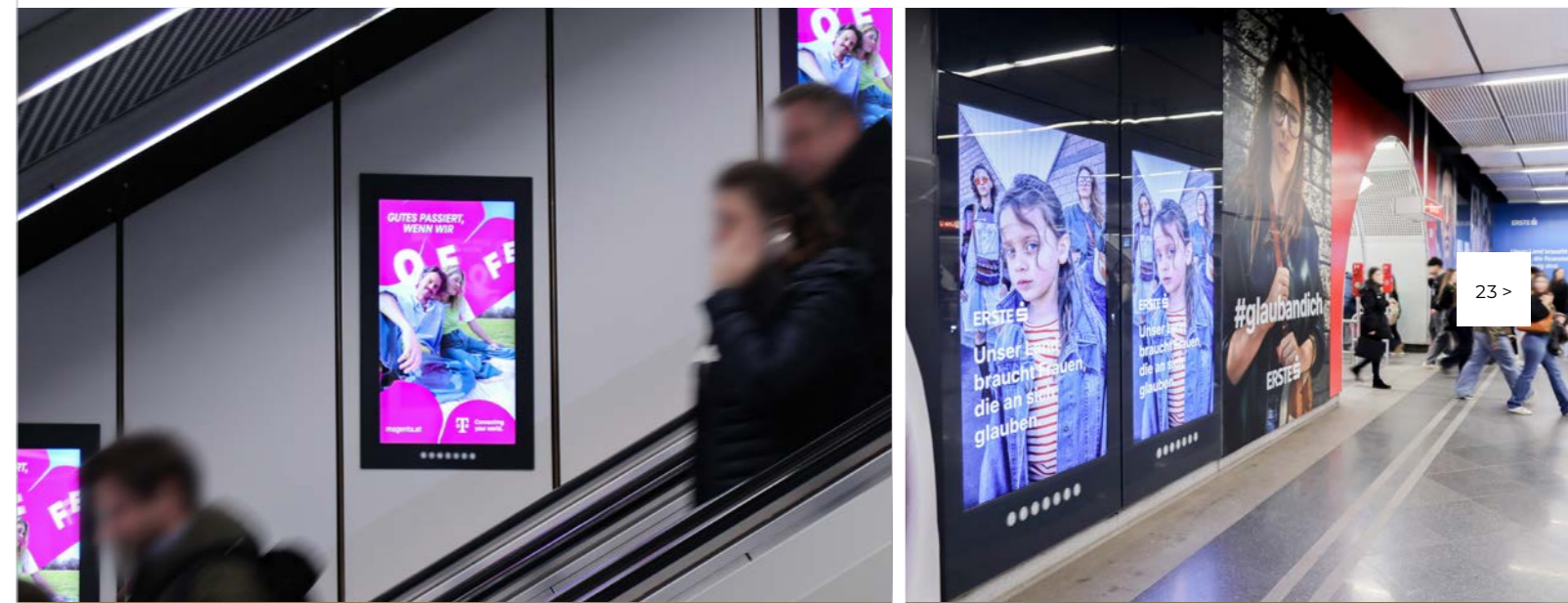

DIGITAL MEDIA - OUTDOOR

Duration 7 days

Prices in Euro | All prices exclude taxes and VAT

Frame Groups		80" DCL	32" DCL	HD-Videowall	TKP
Vienna	City Netz Outdoor 1	6 Units	-	-	9,35
	City Netz Outdoor 2	6 Units	-	-	9,35
	City Netz Outdoor 3	7 Units	-	-	9,35
	City Netz Outdoor 4	6 Units	-	-	9,35
	City Netz Outdoor 5	7 Units	-	-	9,35
	City Netz Outdoor 6	7 Units	-	-	9,35
	Vienna Deluxe	14 Units	-	-	17,65
Salzburg	Deluxe 1	16 Units	-	-	17,65
	Deluxe 2	14 Units	-	-	17,65
Graz	Deluxe small 1	6 Units	-	-	17,65
	Deluxe small 2	6 Units	-	-	17,65
	Deluxe small 3	6 Units	-	-	17,65
Linz	Linz Deluxe 1	8 Units	-	-	17,65
	Linz Deluxe 2	8 Units	-	-	17,65
	Linz City 1	10 Units	-	-	9,35
	Linz City 2	10 Units	-	-	9,35
Klagenfurt	Deluxe	12 Units	-	-	17,65
Bregenz	City	4 Units	-	-	9,35
Innsbruck	Deluxe	6 Units	-	-	17,65
St. Pölten	Deluxe	1 Units	-	-	17,65
Wels	City 1	4 Units	-	-	9,35
	City 2	4 Units	-	-	9,35

80" Digitale City Lights

Duration: 7 days; Spot length: 10 seconds, extended spot length on request.
Image resolution: 1080x1920 px; Visual area: 996x1771 mm.

32" Digitale Escalator Lights

Duration: 7 days; Spot length: 10 seconds, extended spot length on request.
Image resolution: 1080x1920 px; Visual area: 392x697 mm.

2x HD-Videowall Full (1 HD-Videowall consists of 16x46" screens)

Duration: 7 days; Spot length: 10 seconds, extended spot length on request.
Image resolution: 1920x1080 px or 1080x1920 px; Visual area: approx. 3.9x2.3 m.

Handling Fee €515 will be charged 1x per province and up to 3 spots. Data processing and adaptation: costs on demand

EXPLANATION OF TERMS

Starting day Monday.
Special booking upon request.

Handling fee: EUR 515,00
excluding taxes and VAT

Animation flat rate: EUR 2.280,00

Price surcharge:

- 15% seasonal surcharge: 9.11.2026 until incl. start date 14.12.2026
- 30% surcharge for day bookings
- 50% surcharge for hourly bookings
- Surcharge for daypart bookings & booking deals
- No surcharge from 21.12.2026
- 30% if from an existing DCL frame group up to a maximum of 3 screens are excluded
- 80% for bookings of individual DCL units or from the fourth screen of a frame group to be excluded

Exclusion of screens in the area of the 32' DCL escalators is not possible

50% Discount
22. 12. 2025 – 01. 02. 2026
29. 06. 2026 – 30. 08. 2026

30% Discount
02. 02. 2026 – 01. 03. 2026

Spot delivery:
Transport: 5 working days before campaign start.
Outdoor: 10 working days before campaign start.

Animation by Gewista:
Data delivery 10 working days before campaign start.

Technical information upon request.



Premium Screens

Flexible booking

In terms of time, geography & content

No printing costs!
Quick implementation!



< 26



27 >



- Combines the **flexibility** of a digital City Light with the reach and visibility of the Rolling Board
- **Premium locations** with highest contact frequency
- Luminous **"CleanLook"**, perfect alignment
- High presence at city entrances and major **traffic junctions**
- **Flexible booking:** possible by the day or by the hour

PREMIUM SCREENS

Duration 7 days

Prices in Euro | All prices exclude taxes and VAT

Province	Total	TKP	Handling Fee*
Vienna	61 Units	11,40	515,00
Styria	30 Units	11,40	515,00
Upper Austria	17 Units	11,40	515,00
Salzburg	29 Units	11,40	515,00
Tyrol	9 Units	11,40	515,00
Vorarlberg	2 Units	11,40	-
Carinthia	41 Units	11,40	515,00
Lower Austria	4 Units	11,40	515,00

* Data processing and adaptation: costs on demand

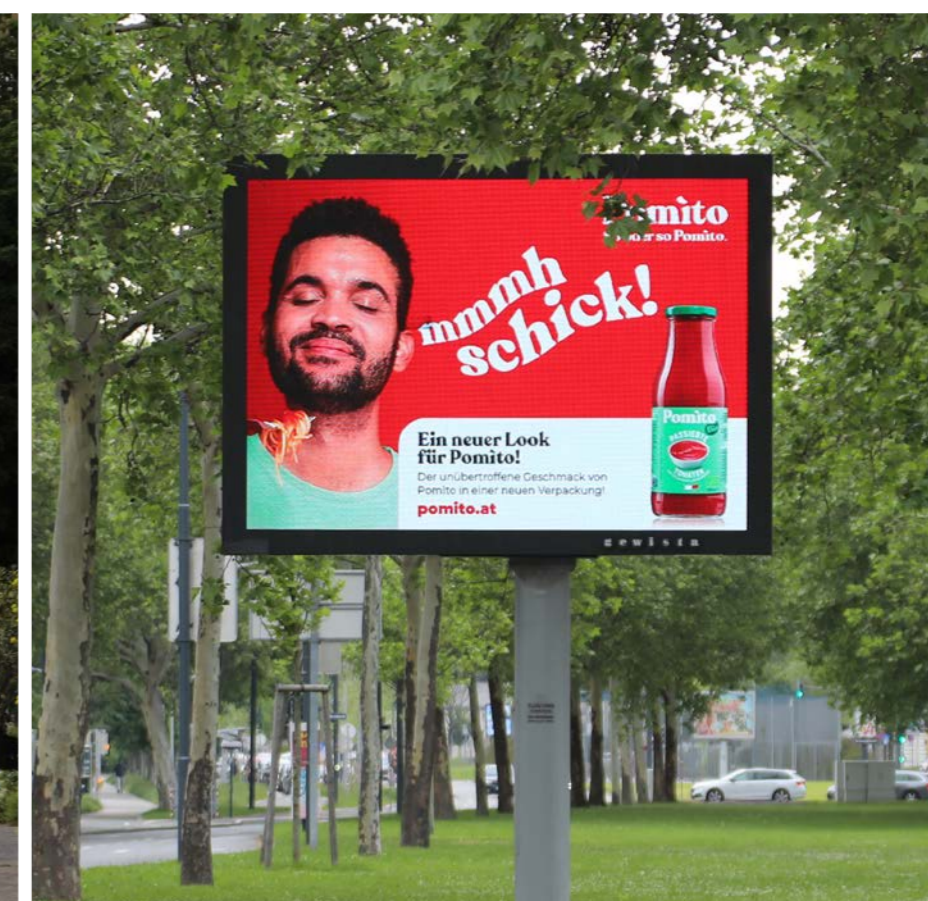

Retail Advertising

Advertisers have the opportunity to showcase their brands in high-impact, high-quality environments in Austria's busiest shopping centers—Westfield Donau Zentrum (DZ), Westfield Shopping City Süd (SCS), Shopping City Seiersberg in Graz, and Europapark Salzburg—using new digital City Lights from Gewista.



We accompany your target group right from the moment they arrive at these premium centers with our selected advertising media.

Promotion, sampling, elevator advertising, and creative, high-impact displays in shopping centers expand our product portfolio. This allows us to increase interaction with your customers and the conversion rate in your store.

Digital City Lights in Austria's four busiest shopping centers with almost 1.2 million shoppers per week

RETAIL ADVERTISING

Duration 6 days

Prices in Euro | All prices exclude taxes and VAT

Frame Groups	Total	TKP	Handling Fee*
Donau Zentrum 1	4 Units	5,90	515,00
Donau Zentrum 2	4 Units	5,90	515,00
Donau Zentrum 3	4 Units	5,90	515,00
Donau Zentrum 4	3 Units	5,90	515,00
Donau Zentrum 5	4 Units	5,90	515,00
Donau Zentrum 6	4 Units	5,90	515,00
Donau Zentrum 7	3 Units	5,90	515,00
Donau Zentrum 8	4 Units	5,90	515,00

Frame Groups	Total	TKP	Handling Fee*
Shopping City Süd 1	4 Units	5,90	515,00
Shopping City Süd 2	4 Units	5,90	515,00
Shopping City Süd 3	4 Units	5,90	515,00
Shopping City Süd 4	4 Units	5,90	515,00
Shopping City Süd 5	4 Units	5,90	515,00
Shopping City Süd 6	4 Units	5,90	515,00
Shopping City Süd 7	4 Units	5,90	515,00

Frame Groups	Total	TKP	Handling Fee*
SC Seiersberg 1	7 Units	5,90	515,00
SC Seiersberg 2	7 Units	5,90	515,00
SC Seiersberg 3	7 Units	5,90	515,00
SC Seiersberg 4	7 Units	5,90	515,00

Frame Groups	Total	TKP	Handling Fee*
Europark 1	8 Units	5,90	515,00
Europark 2	8 Units	5,90	515,00

*Handling fee will be charged 1x per province and up to 3 spots. Data processing and adaptation: costs on demand



CONTENT

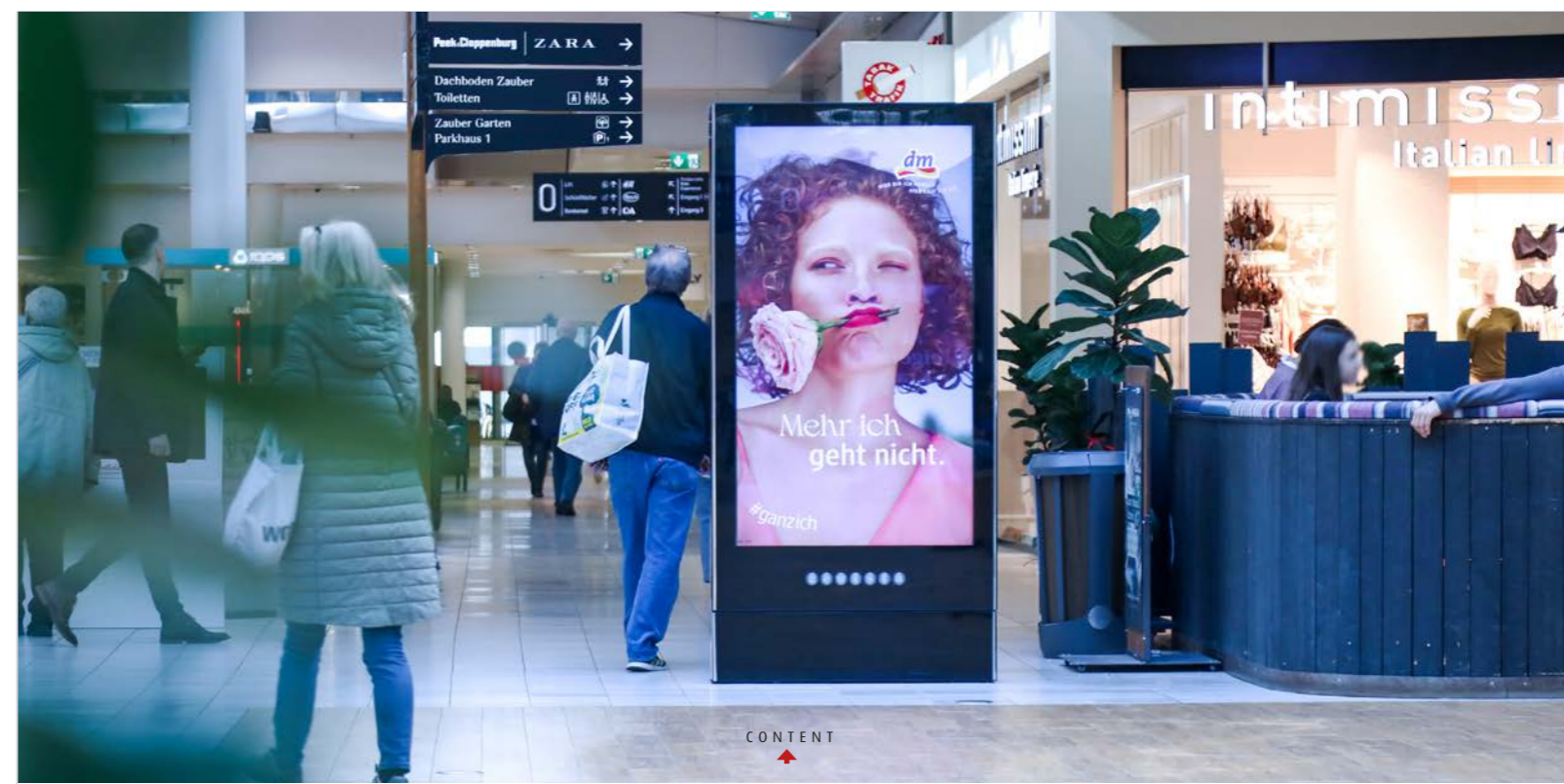

CONTENT

Tram & Bus Advertising

Transport media works and appeals! Whether on trams, buses or underground trains – eye-catching branding is guaranteed to attract attention and leave a positive impression. This is also shown by the latest edition of Ambient-Meter 2025: 79.8% of respondents find advertising on trams very or fairly appealing. 79.5% also rate bus advertising as very or fairly appealing. Transport Media, the hidden champion, creates reach, appeal and genuine brand encounters in everyday urban life.



< 34

35 >



The Austrian bus network shines with its nationwide coverage. The buses are everywhere on the road, they move in both urban and rural areas and thus become a nationwide advertising ambassador.











The mobile advertising spaces are not only cost-effective and efficient, we can also offer them.

Mobile and urban advertising media on the pulse of time.

TRAM

Minimum rental period 1 month

Prices in Euro per product and month | All prices exclude taxes and VAT

Product		NEW			
Number of surfaces/format Width x height in cm per area		Price per day Unit	Rent for 30 days Unit	Handling one-off	Production
Tram advertising* - Low Floor Tram (ULF)					
ULF short Total Look inkl. 20% window covering		224,10	6.723,00	5.839,80	8512,80
ULF long Total Look inkl. 20% window covering		300,70	9.021,00	6.452,60	13.064,00
ULF short Total Look Basic except windows		119,10	3.573,00	4.365,80	5.832,80
ULF long Total Look Basic except windows		167,70	5.031,00	4.856,60	8.703,00
Sky short 6 areas 455 cm x 66 cm		16,60	498,00	862,80	771,80
Sky long 10 areas 455 cm x 66 cm		28,70	861,00	1.440,60	1.276,00
Bar short 8 areas 109 cm x 300 cm		26,60	798,00	2.142,80	1.127,80
Bar long 12 areas 109 cm x 300 cm		37,20	1.116,00	3.242,60	1.662,00
ULF short Sky and Bar Sky: 6 areas, 455 cm x 66 cm Bridge: 8 areas, 109 cm x 300 cm		42,60	1.278,00	2.960,80	1.835,80
ULF long Sky and Bar Sky: 10 areas, 455 cm x 66 cm Bridge: 12 areas, 109 cm x 300 cm		65,20	1.956,00	4.593,60	2.812,00

ULF short with 7 posters for interior advertising - ULF long with 14 posters for interior advertising

* Other formats, including national, available on request.



FLEXITY & SWING CARDS

Minimum rental period 1 month for Flexity

Prices in Euro per product | All prices exclude taxes and VAT

Product		NEW			
Number of surfaces/format Width x height in cm per area		Price per day Unit	Rent for 30 days Unit	Handling one-off	Production
NEU FLEXITY BASELINE		60,00	1.800,00	6.510,00	3.535,00

Swing Cards Tram







Swing Cards | from 500 pieces
10 cm x 21 cm

Various packages available on request



BUS ADVERTISING

Minimum rental period 1 month
 Prices in Euro per product | All prices exclude taxes and VAT

Product Number of surfaces Width x height in cm per area	NEW				
	Price per day Unit	Rent for 30 days Unit	Handling one-off	Production	
ViennaBus*					
Classic Bus Rear 207 cm x 70 cm		9,00	270,00	164,00	91,00
Jumbo Bus Rear 207 cm x 195 cm		29,50	885,00	246,00	502,00
Eco/Total Look (Normal bus) inkl. 20% window covering		60,50	1.815,00	4.285,00	3.513,00
Eco/Total Look (articulated bus) inkl. 20% window covering		83,50	2.505,00	4.935,00	4.554,00
Total Look BASIC (Normal bus) Bus sides & Jumbo Tail		52,50	1.575,00	3.692,00	2.805,00
Total Look BASIC (articulated bus) Bus sides & Jumbo Tail		69,50	2.085,00	4.285,00	3.664,00
City BUS (buses with line guarantee)					
Classic Rear Lines 2A & 3A (alternating) 179 cm x 87 cm		12,00	360,00	180,00	299,00

* Additional national bus booking options available upon request.
 In Vorarlberg there are no advertising opportunities on transport.



Underground Advertising & Brand Area

Underground trams know no delays due to traffic jams or red traffic lights, they run in and out every minute. The time spent in underground stations is therefore very short. And yet advertising messages receive a lot of attention from passengers due to the waiting situation in underground stations, on underground boards, but also in and on the underground trams.



< 40

41 >

Our Brand Areas, also impress not only consumers but also advertisers with its possible applications and attractive pricing. Brand Areas can be booked in different variations at different locations to address the target group with pinpoint accuracy.

The metro is the most favourite public transport of the Viennese people.

UNDERGROUND ADVERTISEMENT

Minimum rental period 1 month
 Prices in Euro per product | All prices exclude taxes and VAT

Product Number of surfaces/format Width x height in cm per area	Price per day Unit	Rent for 30 days Unit	Handling one-off	Production
Underground trams				
Doors V-Waggon (U1+U4 oder U2+U3) ¹⁾ ** 36 pieces 142 cm x 198 cm	117,00	3.510,00	6.436,00	3.709,00
Doors T-Waggon (U6) ¹⁾ ** 24 pieces 149 cm x 215,5 cm	114,00	3.420,00	4.014,00	2.855,00
Totallook T-Waggon (U6) ¹⁾ ** without windows (4 wagons)	446,50	13.395,00	19.212,00	36.020,00
Totallook Basic am V-Waggon ¹⁾ ** 12 pieces	117,50	3.525,00	4.023,00	3.933,00
Roof V-Waggon (U1-U4) * 96 m ²	339,00	10.170,00	5.472,00	3.535,00

¹⁾ Package price
 * V-Waggon (consists of 6 wagons, sketch cannot be shown)
 ** T-Waggon (consists of 4 wagons, sketch cannot be shown)



UNDERGROUND INTERIOR ADVERTISING

Prices in Euro per product
 All prices exclude taxes and VAT

Product Number of surfaces Width x height in cm per area	Price per day Unit	Rent for 30 days Unit	Rent for 30 days Package	Handling one-off	Production Package
Interior advertising					
V-Waggon (U1-U4-U2-U3) ¹⁾ 42 pieces 41 cm x 20 cm, Paper 170 g	0,30	9,00	378,00	268,80	270,00
Underground trams ¹⁾ 750 pieces	0,35	10,50	Various packages upon request		
Swing Cards in der U6					
Swing Cards 3.000 pieces ¹⁾ (Only bookable in this package) 10 cm x 21 cm	883,00	-	-	2.924,00	1.092,00

¹⁾ Package price



BRAND AREA

Minimum rental period 1 week (Monday to Sunday)
 Prices in Euro per product | All prices exclude taxes and VAT

1 Week	Location	m²	Rent per day	Rent per week	Handling one-off	Production	Screens Quantity	Screens Rent per week*
Brand Area								
Stephansplatz	Brand Area Basis	115,00	2.612,14	18.285,00	9.946,00	3.933,00	13	25.543,57
	Brand Area XL	138,00	3.134,57	21.942,00	11.935,00	4.604,00	13	25.543,57
	Escalators 4 & 8	116,00	2.634,86	18.444,00	10.033,00	4.603,00	36	20.095,50
	Escalators 7 & 9	102,50	2.328,21	16.297,50	8.865,00	4.209,00	42	12.056,09
Schottenring incl. CL foil	Half tunnel area	179,50	2.795,07	19.565,50	15.525,00	5.814,00	2	9.669,16
	Entire tunnel area	294,50	4.585,79	32.100,50	25.471,00	9.170,00	2	9.669,16
Karlsplatz	Large: escalator long, Exit passage U1	86,00	1.953,43	13.674,00	7.438,00	3.865,00	29	35.305,62
	Small: escalator short, Exit mezzanine U1	58,00	1.317,43	9.222,00	5.016,00	3.004,00	45	40.328,21
Schwedenplatz	Brand Area Basis & Escalators 3	79	1.794,43	12.561,00	6.703,00	3.650,00	19	10.234,10
	Escalators 1	73	1.658,14	11.607,00	6.314,00	3.465,00	24	11.831,83
	Escalators 2	70	1.590,00	11.130,00	6.054,00	3.373,00	24	11.176,53
	Escalators 4 & 5	96	2.180,57	15.264,00	8.303,00	4.173,00	32	18.037,40
Praterstern	long corridor to U1-right side	77,50	1.472,50	10.307,50	6.703,00	2.963,00	4	8.894,80
Messe	Entrance + Exit Messe	105,00	1.995,00	13.965,00	9.081,00	4.125,00	-	-
Krieau	Exit Trabrennstraße	90,00	1.710,00	11.970,00	7.784,00	3.831,00	-	-
Rochusgasse	Exit Rochusmarkt	30,00	Various packages upon request		2.388,00	2.213,00	-	-
Hauptbahnhof/ Südtirolerplatz	Tunnel at the U1 platform	94,00	1.786,00	12.502,00	8.130,00	3.470,00	-	-
Westbahnhof	Complete	156,00	2.964,00	20.748,00	13.492,00	5.770,00	16	4.070,56
Zieglergasse Exit	Schottenfeldgasse	59,00	1.121,00	7.847,00	5.103,00	2.877,00	-	-
	Webgasse	58,00	1.102,00	7.714,00	5.016,00	2.846,00	-	-
	Andreasgasse	59,50	1.130,50	7.913,50	5.146,00	2.893,00	-	-
	Otto Bauer Gasse	58,50	1.111,50	7.780,50	5.060,00	2.862,00	-	-
Neubaugasse	Brand Area Exterior	58,50	1.111,50	7.780,50	5.060,00	2.862,00	-	-
	Exits indoor	121,00	2.299,00	16.093,00	10.465,00	4.592,00	-	-
Kaisermühlen	Side DC total	85,00	1.615,00	11.305,00	7.352,00	3.193,00	-	-
Kagran	Escalators DZ	7,00	-	-	557,00	1.294,00	-	-
Schwedenplatz	4 columns	40,00	-	-	2.475,00	1.909,00	-	-
Hauptbahnhof	5 columns	25,00	-	-	2.633,00	1.414,00	-	-

*Handling Fee €515 will be charged 1x per province and up to 3 spots. Data processing and adaptation: costs on demand

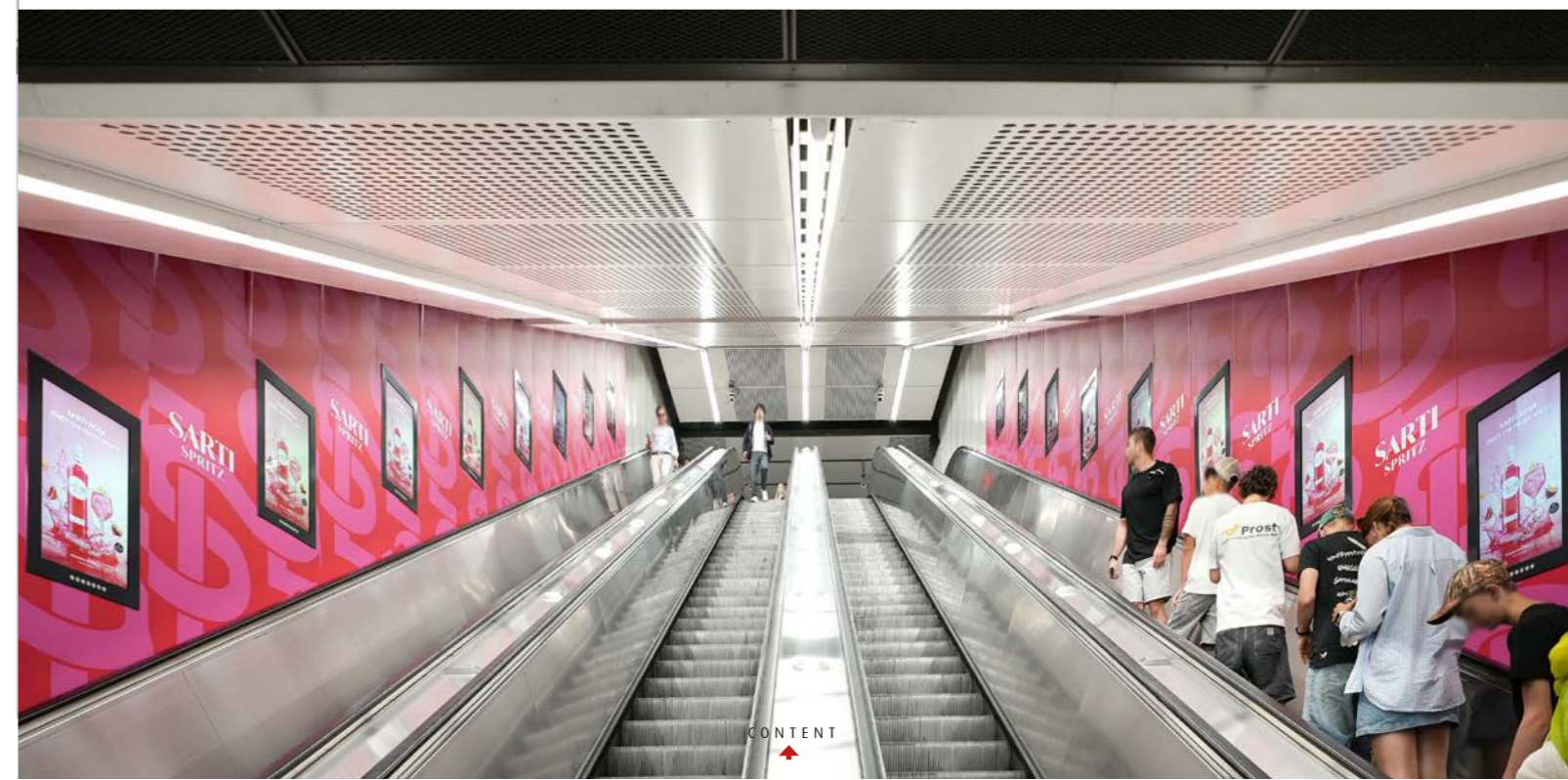

Permanent advertising

KEEP YOUR BRAND IN VIEW!

If you want to establish a strong, lasting presence in public spaces, choose advertising spaces with high visibility and recognition value: City Light Information boards and classic Information boards showcase your company around the clock, providing an impressive calling card in the heart of urban life.

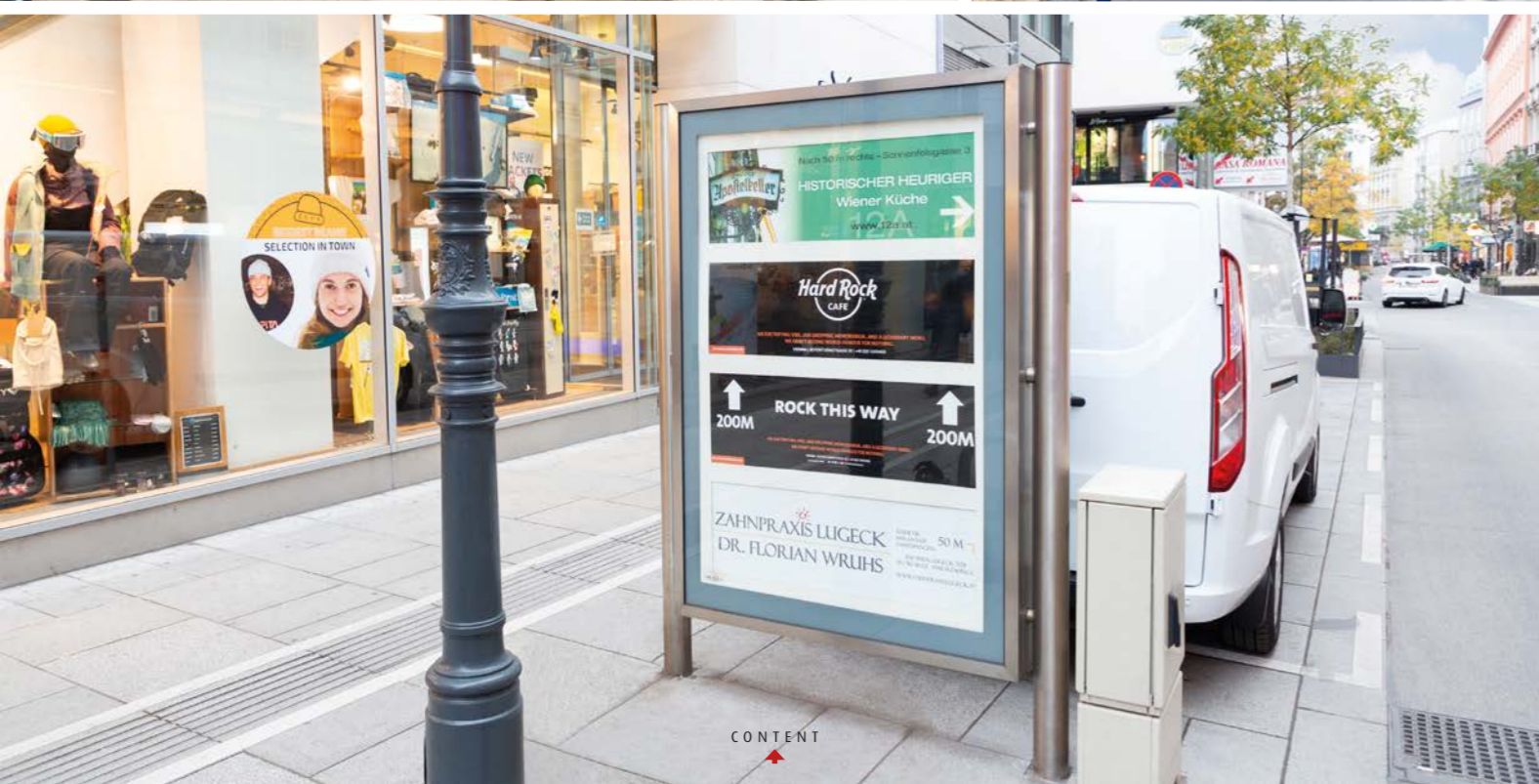

You can also be visible beneath the city: with an underground panel, you can place your brand where thousands of people pass by every day. These eye-catching formats are not only signposts, but real attractions that lead your target group directly to your business premises.

With permanent advertising, you remain visible—day after day, glance after glance.

*VISIBLE
24 HOURS A DAY,
7 DAYS A WEEK,
365 DAYS A YEAR*

ADVERTISING MEDIA ON A PERMANENT BASIS

Prices in Euro per product and month
All prices exclude taxes and VAT

Product	Rent Premium ²⁾	Rent Standard	Assembly/disassembly	Cost contribution/foiling one-off	Production
Information boards/ advertising boards ¹⁾	88,00	43,00	218,00	177,00	114,00
Ring board	130,00	-	436,00	354,00	192,00

PERMANENT ADVERTISING

Boards, city lights and showcases can be booked for a minimum rental period of 12 months

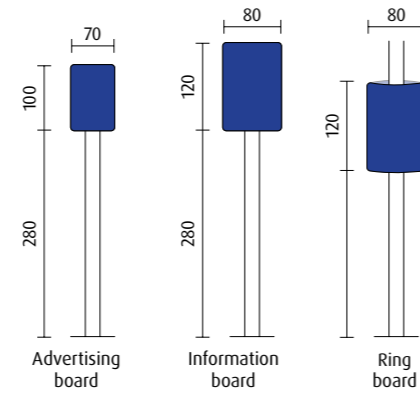

¹⁾ Vienna, Vösendorf; other provinces on request.
²⁾ Vienna, excluding Ring and Gürtel addresses



Underground panels	Format W x H in cm per area	Rent	Assembly/disassembly	Cost contribution/foiling one-off	Production
Premium**	Folie 120 cm x 170,5 cm	153,00	239,00	195,00	168,00
Standard	Folie 120 cm x 170,5 cm	110,00	239,00	195,00	168,00

PERMANENT ADVERTISING

Panels can be booked for a minimum rental period of 12 months

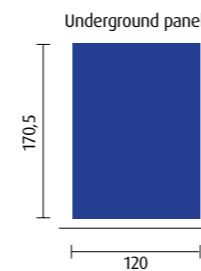

**U1: Karlsplatz, Stephansplatz, Schwedenplatz, Hauptbahnhof / Südtiroler Platz
**U2: Volkstheater, Schottentor, Schottenring, Messe / Prater, Krieau
**U3: Wien Mitte / Landstraße, Stubentor, Stephansplatz, Herrengasse, Volkstheater, Neubaugasse, Zieglergasse, Westbahnhof
**U4: Schwedenplatz, Schottenring, Wien Mitte / Landstraße, Karlsplatz
**U6: Westbahnhof, Michelbeuern / AKH

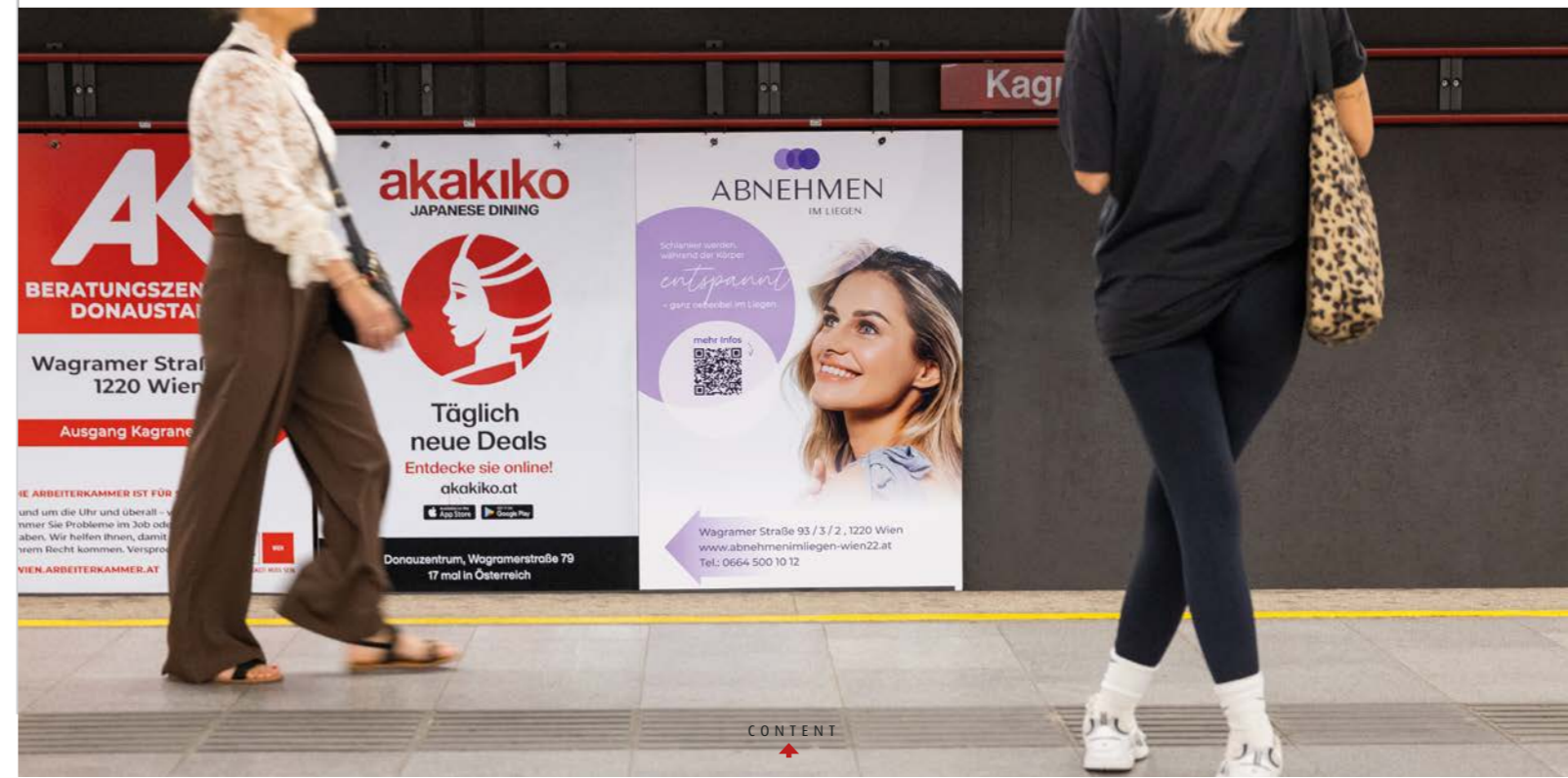

ADVERTISING MEDIA ON A PERMANENT BASIS

Prices in Euro per product and month
All prices exclude taxes and VAT

City Light	Rent Premium ²⁾	Rent Standard	Assembly/disassembly	Cost contribution/foiling one-off	Production
City Light Information boards	-	145,00	177,00	-	103,00

PERMANENT ADVERTISING

City Light Information boards can be booked for a minimum rental period of 12 months.

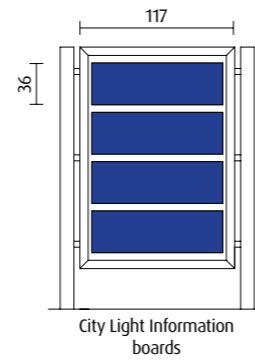

Product	Rent SCS Premium ²⁾	Rent Standard	Assembly/disassembly	Cost contribution/foiling one-off	Production
City Light	572,00	510,00	25,00	15,30	167,00
Billboard 16**	478,00	311,00	582,00*	-	1.169,00
Billboard 24**	707,00	555,00	666,00*	-	1.751,00

*The prices for assembly and disassembly are based on the valid price list for the current calendar year at the time of booking or cancellation.

**Aluminum panel

PERMANENT ADVERTISING

Minimum rental period 3 months

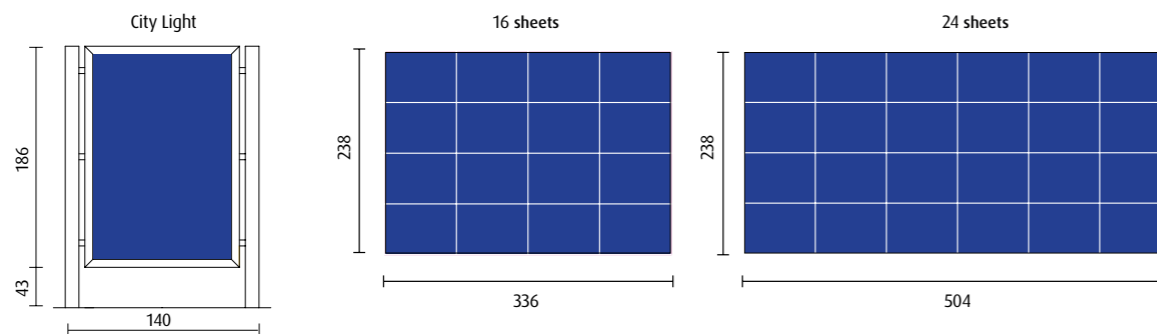

Mobile Advertising

Mobile advertising media that can be transported to the desired location as requested offer pure flexibility. No location is too unusual. City Light, Digital City Light, Rolling Board, advertising column, trapeze stone and mobile stands are consistently able to garner attention for your message.

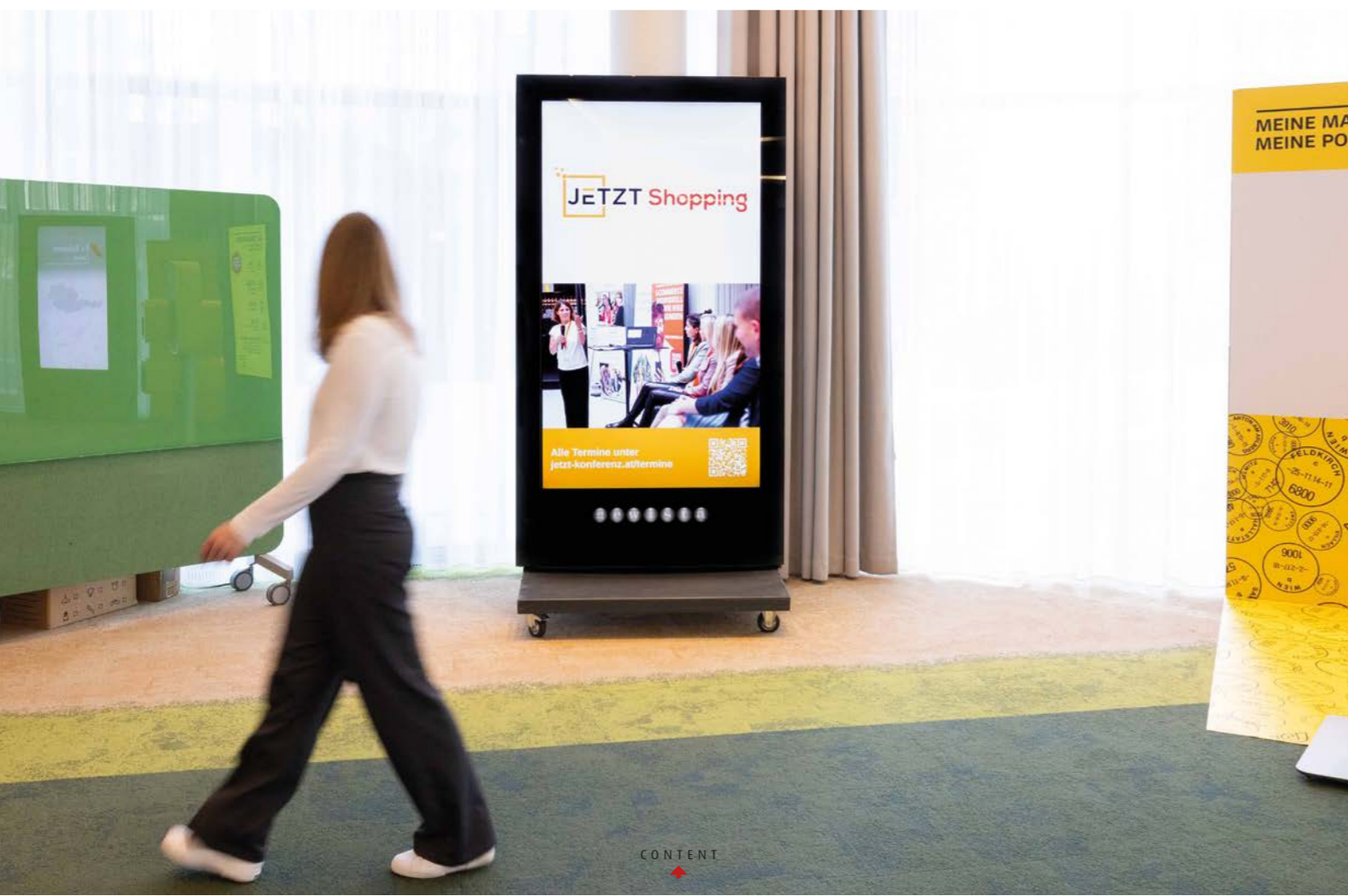

This is where brand names, logos or other important messages are always put in the right light, thus increasing your on-site presence.

More information upon request.

Megaboard

“We go MEGA”, we always strive to offer the largest and most exclusive advertising spaces and try to find the optimal outdoor advertising solution for our clients. This is possible through our extensive product portfolio: MEGAscreens, MEGAscaffolding, MEGAfacades, and MEGABoards. For example, we develop long-term advertising concepts and directional systems by assessing the local situation and including your competitors.



< 54



55 >



CONTENT

Thanks to our years of experience and our expert team, we are your primary contact for large-scale advertising.

www.megaboard.at

Infoscreen

INFOSCREEN is a highly responsive Digital Out of Home Program medium in the underground, trams and buses. With 4,851 INFOSCREENS in almost all provincial capitals of Austria, as well as in Wels and Steyr INFOSCREEN is one of Austria's largest mass media outlets with a national daily reach of over 11%.



INFOSCREEN reaches 921,000 individuals daily who are interested in staying informed about world events, politics, culture, sports, and events. In Vienna alone, INFOSCREEN reaches approximately one-third of the city's population in the 14+ target group with a daily reach of 32.7 percent.

INFOSCREEN – your digital Out of Home medium
 INFOSCREEN informs and entertains the public waiting for public transport and shortens waiting and travel times.

www.infoscreen.at

KULTURFORMAT

In the art and cultural hub of Vienna, numerous exhibitions, performances, and other cultural events take place daily. Thus, it requires optimal promotion to successfully spotlight one's own event.



KULTURFORMAT GmbH offers a diverse portfolio of advertising opportunities in the Out of Home sector. From classic cultural columns to analog and digital city lights, underground stations, mini posters on lampposts, to big boards, transport media and telelights. Flexible and individually designed service packages adapt optimally to the available budget.

The “sweetener” for the Viennese cultural scene: is the “Cost-Free Spaces” initiative, of KULTURFORMAT to enable free advertising on switch boxes when financial resources for promotion are limited.

www.kulturformat.at

OOH International

Gewista is also active in the surrounding Central and Eastern European countries. In the Czech Republic, Slovakia, Croatia, Slovenia and Hungary, Gewista's subsidiaries are market leaders in the Street Furniture sector. Gewista is a partner company of JCDecaux, the world market leader in outdoor advertising, which is active in more than 80 countries. Therefore, countries such as Ukraine, Poland, Bulgaria, Kazakhstan, Uzbekistan and Azerbaijan are also served from our headquarters in Vienna.

In addition, we offer out-of-home solutions in all countries of the JCDecaux portfolio worldwide.

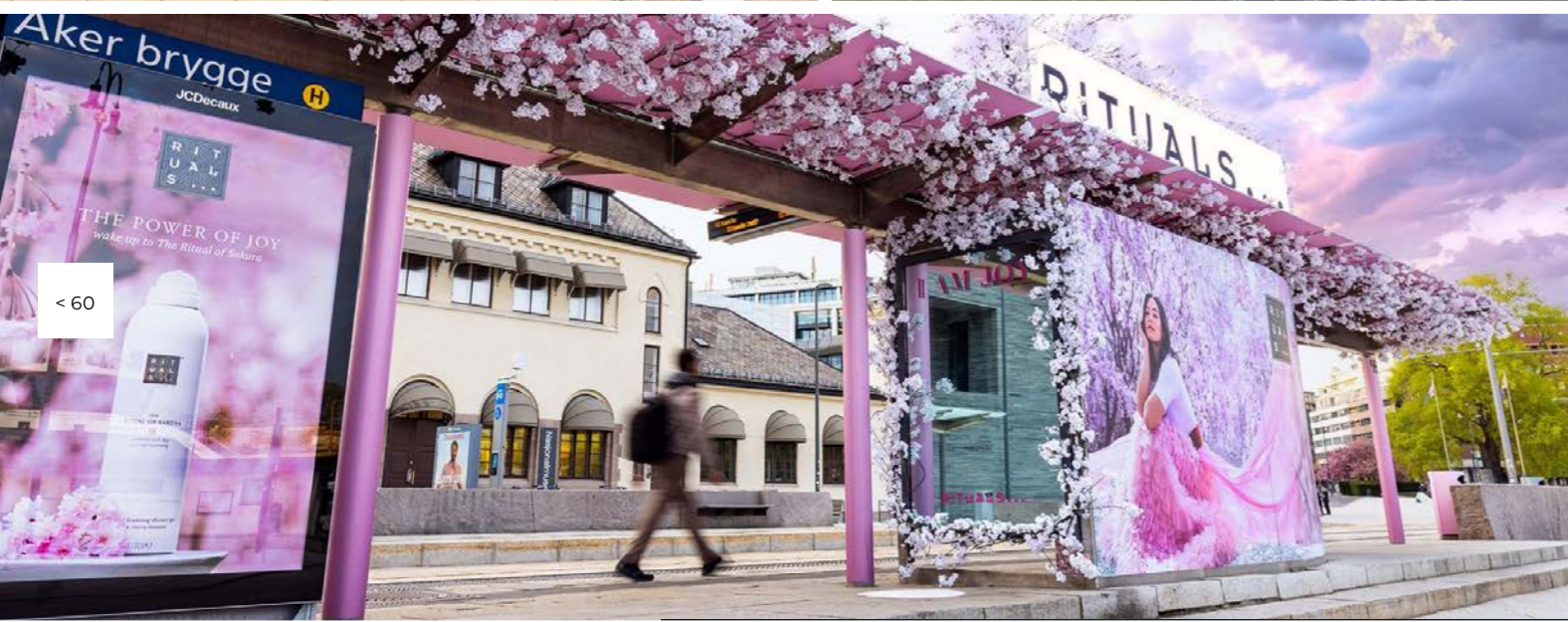

More information at www.jcdecaux.com

YOUR GEWISTA-TEAM

Name	Department	Phone	E-mail
Franz Solta	Managing Director/CEO	+43 1 79 5 97-600	ceo@gewista.at
Andrea Groh	Commercial Procurement/CSO	+43 1 79 5 97-661	andrea.groh@gewista.at
Hansjörg Hosp	Commercial Procurement/COO	+43 1 79 5 97-650	hansjoerg.hosp@gewista.at
Mag. (FH) Bernd Sorger	Commercial Procurement/CFO	+43 1 79 5 97-613	bernd.sorger@gewista.at
Florian Wagner	CDO	+43 1 79 5 97-632	florian.wagner@gewista.at

Sales

Mag. Theresa Sternbach	Head of Sales	+43 676 669 54 12	theresa.sternbach@gewista.at
Mario Filipovic	Group Head Sales	+ 43 676 707 29 27	mario.filipovic@gewista.at
Mag. (FH) Alexander Groß, MBA MSc	Senior Key Account Manager	+43 676 661 51 47	alexander.gross@gewista.at
Torsten Korn	Senior Key Account Manager	+43 676 689 75 20	torsten.korn@gewista.at
Michael Reiser	Senior Key Account Manager	+43 676 636 59 62	michael.reiser@gewista.at
Pia Scharbau	Senior Key Account Manager	+43 676 419 38 85	pia.scharbau@gewista.at
Mag. Gerald Schütz	Senior Key Account Manager	+43 676 636 59 57	gerald.schuetz@gewista.at
Michael Wehofer, MSc	Senior Account Manager	+43 676 66 25 683	michael.wehofer@gewista.at
Reinhard Benesch	Senior Account Manager	+43 676 479 05 05	reinhard.benesch@gewista.at
Kathrin Klimpfinger	Key Account Manager	+43 676 391 35 35	kathrin.klimpfinger@gewista.at
Mag. Andreas Miksik	Key Account Manager Programmatic Advertising	+43 676 691 05 37	andreas.miksik@gewista.at
Alexander Kunak	Account Manager	+43 676 479 04 32	alexander.kunak@gewista.at
Alp Cakmak	Account Manager Stadtwerbung	+43 676 66 88 451	alp.cakmak@gewista.at
Paul Zamfir	Account Manager Stadtwerbung	+43 676 659 31 57	paul.zamfir@gewista.at

Logistics

Michael Hauzinger	Head of Logistics	+43 1 79 5 97-509	michael.hauzinger@gewista.at
Rene Nürnbergger	Group Head Plakat & City Light	+43 1 79 5 97-458	rene.nuernberger@gewista.at
Claudia Senftner	Group Head / Organisation & Quality Control	+43 1 79 5 97-652	claudia.senftner@gewista.at
Ralf Nürnbergger	Group Head Premium Board	+43 664 816 52 72	ralf.nuernberger@gewista.at

Should you not know who can assist you, we look forward to receiving your enquiry at sales@gewista.at



Pricelist 2026
POSTING CALENDER 2026

2026	KW	MONDAY	TUESDAY	WEDNESDAY	THURSDAY	FRIDAY	SATURDAY	SUNDAY
Dec./Jan.	KW 1	29.12.	30.12.	31.12.	1.1.	2.1.	3.1.	4.1.
January	KW 2	5.1.	6.1.	7.1.	8.1.	9.1.	10.1.	11.1.
January	KW 3	12.1.	13.1.	14.1.	15.1.	16.1.	17.1.	18.1.
January	KW 4	19.1.	20.1.	21.1.	22.1.	23.1.	24.1.	25.1.
Jan./Feb.	KW 5	26.1.	27.1.	28.1.	29.1.	30.1.	31.1.	1.2.
February	KW 6	2.2.	3.2.	4.2.	5.2.	6.2.	7.2.	8.2.
February	KW 7	9.2.	10.2.	11.2.	12.2.	13.2.	14.2.	15.2.
February	KW 8	16.2.	17.2.	18.2.	19.2.	20.2.	21.2.	22.2.
Feb./Mar.	KW 9	23.2.	24.2.	25.2.	26.2.	27.2.	28.2.	1.3.
March	KW 10	2.3.	3.3.	4.3.	5.3.	6.3.	7.3.	8.3.
March	KW 11	9.3.	10.3.	11.3.	12.3.	13.3.	14.3.	15.3.
March	KW 12	16.3.	17.3.	18.3.	19.3.	20.3.	21.3.	22.3.
March	KW 13	23.3.	24.3.	25.3.	26.3.	27.3.	28.3.	29.3.
Mar./April	KW 14	30.3.	31.3.	1.4.	2.4.	3.4.	4.4.	5.4.
April	KW 15	6.4.	7.4.	8.4.	9.4.	10.4.	11.4.	12.4.
April	KW 16	13.4.	14.4.	15.4.	16.4.	17.4.	18.4.	19.4.
April	KW 17	20.4.	21.4.	22.4.	23.4.	24.4.	25.4.	26.4.
April/May	KW 18	27.4.	28.4.	29.4.	30.4.	1.5.	2.5.	3.5.
May	KW 19	4.5.	5.5.	6.5.	7.5.	8.5.	9.5.	10.5.
May	KW 20	11.5.	12.5.	13.5.	14.5.	15.5.	16.5.	17.5.
May	KW 21	18.5.	19.5.	20.5.	21.5.	22.5.	23.5.	24.5.
May	KW 22	25.5.	26.5.	27.5.	28.5.	29.5.	30.5.	31.5.
June	KW 23	1.6.	2.6.	3.6.	4.6.	5.6.	6.6.	7.6.
June	KW 24	8.6.	9.6.	10.6.	11.6.	12.6.	13.6.	14.6.
June	KW 25	15.6.	16.6.	17.6.	18.6.	19.6.	20.6.	21.6.
June	KW 26	22.6.	23.6.	24.6.	25.6.	26.6.	27.6.	28.6.
June/July	KW 27	29.6.	30.6.	1.7.	2.7.	3.7.	4.7.	5.7.

Campaign start	Premium Board	Billboard	City Light	Digital Media
Posting days	Premium Board	Billboard	City Light	Follow-up days Billboard



CONTENT

Pricelist 2026
POSTING CALENDER 2026

2026	KW	MONDAY	TUESDAY	WEDNESDAY	THURSDAY	FRIDAY	SATURDAY	SUNDAY
July	KW 28	6.7.	7.7.	8.7.	9.7.	10.7.	11.7.	12.7.
July	KW 29	13.7.	14.7.	15.7.	16.7.	17.7.	18.7.	19.7.
July	KW 30	20.7.	21.7.	22.7.	23.7.	24.7.	25.7.	26.7.
July/August	KW 31	27.7.	28.7.	29.7.	30.7.	31.7.	1.8.	2.8.
August	KW 32	3.8.	4.8.	5.8.	6.8.	7.8.	8.8.	9.8.
August	KW 33	10.8.	11.8.	12.8.	13.8.	14.8.	15.8.	16.8.
August	KW 34	17.8.	18.8.	19.8.	20.8.	21.8.	22.8.	23.8.
August	KW 35	24.8.	25.8.	26.8.	27.8.	28.8.	29.8.	30.8.
Aug./Sept.	KW 36	31.8.	1.9.	2.9.	3.9.	4.9.	5.9.	6.9.
September	KW 37	7.9.	8.9.	9.9.	10.9.	11.9.	12.9.	13.9.
September	KW 38	14.9.	15.9.	16.9.	17.9.	18.9.	19.9.	20.9.
September	KW 39	21.9.	22.9.	23.9.	24.9.	25.9.	26.9.	27.9.
Sept./Oct.	KW 40	28.9.	29.9.	30.9.	1.10.	2.10.	3.10.	4.10.
October	KW 41	5.10.	6.10.	7.10.	8.10.	9.10.	10.10.	11.10.
October	KW 42	12.10.	13.10.	14.10.	15.10.	16.10.	17.10.	18.10.
October	KW 43	19.10.	20.10.	21.10.	22.10.	23.10.	24.10.	25.10.
Oct./Nov.	KW 44	26.10.	27.10.	28.10.	29.10.	30.10.	31.10.	1.11.
November	KW 45	2.11.	3.11.	4.11.	5.11.	6.11.	7.11.	8.11.
November	KW 46	9.11.	10.11.	11.11.	12.11.	13.11.	14.11.	15.11.
November	KW 47	16.11.	17.11.	18.11.	19.11.	20.11.	21.11.	22.11.
November	KW 48	23.11.	24.11.	25.11.	26.11.	27.11.	28.11.	29.11.
Nov./Dec.	KW 49	30.11.	1.12.	2.12.	3.12.	4.12.	5.12.	6.12.
December	KW 50	7.12.	8.12.	9.12.	10.12.	11.12.	12.12.	13.12.
December	KW 51	14.12.	15.12.	16.12.	17.12.	18.12.	19.12.	20.12.
December	KW 52	21.12.	22.12.	23.12.	24.12.	25.12.	26.12.	27.12.
Dec./Jan.	KW 1	28.12.	29.12.	30.12.	31.12.	1.1.	2.1.	3.1.

Print data deadline: 3 weeks + 2 business days before campaign launch (25 days total)

Delivery deadline: 2 weeks before campaign launch (14 days)

* Exception for posters: Due to public holidays, adjusted print data deadlines (DU) and delivery deadlines apply to these start dates.



CONTENT

1. GENERAL

These General Terms and Conditions apply to contracts between Gewista Werbegeellschaft m.b.H. (“**GEWISTA**”) and entrepreneurs (“**Clients**”). They do not apply to consumers.

2. ADVERTISING MEDIA

These General Terms and Conditions apply to the following advertising media: Posters (“**P**”), City Light (“**CL**”), Premium Board, which is a glazed and backlit advertising medium (“**PB**”), City Light Changer, which is a CL equipped with a changing technology that enables multiple occupancy (“**CW**”), Transport Media, Brand Area and Station Branding (“**TM**”), Subway Boards and other permanent advertising (“**DW**”), Mobile Advertising (“**MW**”), Digital Media, which are Digital Out of Home media (“**DM**”), and special forms of advertising and innovations.

3. OFFER AND ACCEPTANCE OF ORDERS

Offers made by GEWISTA are subject to change (non-binding). Acceptance of orders by GEWISTA and changes to orders must be made in writing (by email or online via our booking platform). GEWISTA reserves the right to reject orders without giving reasons. The transfer of booked advertising space to third parties is not permitted.

4. GRAPHIC DESIGN

The content, technical form, scope, material, appearance and color of the advertisement must comply with the official regulations and those of the vehicle operator and the maintenance provider for the space. The relevant specifications can be found in the printed data sheet provided in the case of TM and in the animation guidelines and data sheet for data delivery in the case of DM. For all other advertising media, the production details can be found in the order documents. Upon delivery, all printed advertising materials become the property of GEWISTA. The client must deliver the printed advertising materials in the following quality, using non-reflective colors, 14 working days before the start of installation, free of charge (delivery address as per the shipping list provided by GEWISTA), as follows:

Special features for P: 100-115 g/m², wood-free, single-sided, smooth, Bluebac, flat on pallet, sorted by sheets. Interleaves must be placed between the different parts; 15% replacement billboards. For billboards, a gluing sketch must be provided to ensure accurate order execution. For billboard formats that do not correspond to the dimensions or Austrian-Standards (O-Norm) or to the order, there may be additional charges for gluing and paper. The following poster formats are considered to be in accordance with Austrian-Standard A 1001: 1/1 sheet 84 x 59.5 cm, 2/1 sheet 119 x 84 cm, 4/1 sheet 168 x 119 cm, 8/1 sheet 238 x 168cm, 16/1 sheet 238 x 336 cm, 24/1 sheet 238 x 504 cm, 48/1 sheet 238 x 1,008 cm, special formats by prior agreement. [g/m² = grams per square meter]

Special features for CL: Coated offset paper, white, matte, wood-free, translucent throughout, with a grammage (grams per square meter) of at least 130g/m² to a maximum of 150g/m², not creased, flat on pallet; 15% replacement billboards. The production size is 118.5 x 175 cm (in one piece, portrait format). The unrestricted viewing area is 104 x 161.5 cm (portrait format). Small print runs of up to 20 pieces, film foils (large slides), can also be used if they correspond to the specified size. When delivering different items, the corresponding identification numbers must be printed in the upper left corner of the advertising material.

Special features for PB: 170-200g/m², flat on pallet with the front of the billboards facing downwards. Smaller print runs of up to 25 pieces can also be delivered rolled up on cardboard rolls. Wooden panels must be used as inserts between the pallets. The subject must be created in 314 x 231 cm format. The lettering and the most important elements of the subject must be placed within the unrestricted viewing area of 300 x 216 cm, as the subject is partially covered by a running passepartout (frame matte) within a 7 cm frame. Single-piece printed posters must be delivered cut to size at 317 x 234 cm.

Special features for DM: For DM, the advertising material is displayed via Digital Out-of-Home media. Advertising material must be provided by the client in accordance with GEWISTA's specifications as set out in the animation guidelines and the data delivery data sheet which is enclosed with the order confirmation. The client is responsible for ensuring that the advertising material is received on time and is free of errors or defects. In the case of dynamic content, the client must submit the storyboard, concept, or idea to GEWISTA for planning and preparation at least six weeks before the start of the campaign. For Direct Out of Home media, the advertising templates must be received by GEWISTA in the agreed-upon form at least 10 working days before the first placement date. In the case of a recognizably unsuitable or visibly damaged template, GEWISTA shall notify the client immediately. GEWISTA approves the content for direct and programmatic Digital Out of Home campaigns. Moderation (meaning approval of the content and content structure) of dynamic content campaigns is mandatory and must comply with GEWISTA's animation guidelines. Moderation is carried out by the client or, by separate, prior agreement, by GEWISTA. The animation guidelines are available at the www.gewista.at website. In the case of dynamic content campaigns, the client is responsible for ensuring that data

(e.g., photos, etc.) are never displayed without prior approval. When booking a brand area, GEWISTA is permitted to reduce the scope of existing orders on Digital City Lights that are part of a brand area, with an equivalent reduction in budget. GEWISTA guarantees that the booked VAC/Verified Audience Contacts will be achieved within the booked period within the scope of the GEWISTA inventory.

Special features for TM: The use of adhesive letters, fluorescent colors, and reflective colors is not permitted. Removable, opaque, certified films approved by the inventory provider must be used as the substrate. QR codes are not permitted in the design of swing cards and brand areas on escalators.

Special features for DW: The use of adhesive letters, fluorescent colors, and reflective colors is not permitted. Removable, self-adhesive, opaque, and glossy-laminated adhesive films must be used as the substrate. The minimum durability should be 3-5 years. Any similarity between the information boards and official traffic signs is not permitted. If permits are required for the desired locations, the client shall bear the respective costs of the permit procedure (information available upon request) per board, even in the event of rejection. Delivery address: GEWISTA Technik – Lager, Franzosengraben 5, 1030 Vienna Delivery times: Monday-Thursday 6:00 a.m.-2:00 p.m., Friday 6:00 a.m.-11:30 a.m.

Special features for special advertising formats and innovations: Special advertising formats can only be implemented in conjunction with a supplementary campaign. The implementation of a special advertising format is at the client's risk; this also applies in the event of vandalism and theft. Due to particular specifications in the implementation, longer set-up times may occur, which may differ from GEWISTA's display calendar. For the planning of the final assembly, a prototype or its print data, including a position-sketch or mock-up, must be made available to GEWISTA in print-ready form no later than four weeks before the start of the campaign. Production costs are approximate and can only be determined after the final print data is available and after a prototype has been produced/delivered. If GEWISTA develops a prototype, live testing is allowed to take place during the booked, actual running time. Installation costs apply to the Vienna area. Due to structural differences between individual locations, adjustments may be necessary on-site. Likewise, third-party specifications may result in short-term changes to the locations. The use of technical equipment that is not owned by GEWISTA cannot be assumed for implementation purposes. Due to cooperation with partner companies and public authorities, additional approvals from these parties may be necessary in special cases. In the case of sampling, any cleaning costs incurred because of products provided or third-party companies will be charged separately, if necessary. Any product-specific storage that may be required must be provided by the customer. For events held in buildings, the guidelines of the maintenance provider and operator apply. GEWISTA shall be held harmless in this regard.

5. DISPLAY

Advertising material shall be displayed exclusively by GEWISTA employees or by companies commissioned by GEWISTA. Details on display duration and minimum terms can be found in the current GEWISTA price list/display calendar. Costs for displays outside the display calendar must be agreed upon separately and borne by the client. Minor delays are possible for technical reasons (Sundays or public holidays at the start of the booked display period, weather, strong winds). Display on a specific date cannot be guaranteed. In the event of strong winds, periods of cold and rain, natural disasters, exceptional weather conditions, and outdoor temperatures below +5°C (foil adhesion), GEWISTA shall be released from its obligation to perform while retaining its claim to payment. GEWISTA shall notify the client of such circumstances within a reasonable period of time. No liability is accepted for changes in the color of advertising materials resulting from the use of certain printing inks or from weather conditions. No liability is assumed. Unless otherwise agreed in writing, affixing/removal (TM) may take place at GEWISTA five working days before or after the start of the order, depending upon the volume of work. The installation of an underground billboard may take up to 8 weeks after delivery of the film. Extensions due to installation restrictions imposed by WIENER LINIEN GmbH & Co KG (“**Wiener Linien**”) are reserved. Blocking periods (adhesion/display not before a certain date) must be communicated to GEWISTA in writing up to 14 working days before the start of the order and may result in additional costs.

6. NO EXCLUSION OF COMPETITION

Exclusion of competition cannot be guaranteed.

7. TERM IN THE EVENT OF DELAYED DELIVERY OF ADVERTISING MATERIAL

In the event of delayed delivery of advertising material by the client, timely and complete fulfillment of the order cannot be guaranteed. In this case, the term will not be extended, but will be invoiced as specified in the order. Any desired deviation from the official posting according to the display calendar/order documents must be requested in writing at least 10 working days before the start of the posting and may result in additional costs to the client.

8. RELOCATION OF ADVERTISING MEDIA

GEWISTA is entitled, at its own discretion, to change the booked locations and carry out relocations in order to make better use of posting or display space or to improve the quality of the location. However, the relocation of the advertising announcement must not lead to a deterioration in the confirmed impressions. This condition does not apply in cases where relocation is necessary for justified reasons, such as dismantling or conversion of the advertising space, short-term restrictions on visibility, etc. In this case, only the effectively fulfilled impressions will be charged.

9. AREAS OF USE OF THE VEHICLES AT TM

The respective areas of operation/routes of the vehicle or route networks of the vehicle operator are specified in the order. GEWISTA cannot provide the client with continuous proof of use of the respective vehicle. The client acknowledges that GEWISTA cannot guarantee uniform and consistent use of the means of transport, because shifts may occur within the motor vehicle routes of the transport operator. Changes to vehicle schedules and deviations from the area of use may occur for operational reasons (maintenance, repairs, acute damage, etc.). Such operational necessities must be given priority. In such cases, recourse against GEWISTA and the transport companies is excluded. If another vehicle within a transport company breaks down during a route operation due to a defect, the vehicle with the client's advertising may be used as a replacement vehicle, thereby temporarily changing its agreed-upon operating area, which shall not enable or allow any claims for damages by the client. GEWISTA cannot restrict a vehicle to exclusive use on a single route or influence the frequency of use on individual routes (except for limited route guarantees). GEWISTA only grants a limited route guarantee for exterior vehicle advertising on Wiener Linien trams (a.k.a. streetcars or trolleys) to the following extent:

- Wiener Linien provides a limited guarantee for two trams — restricted to 20 days per month — per approved line route that vehicles with corresponding exterior advertising will only run on the specified line.
- This guarantee may be revoked by Wiener Linien at any time for operational reasons.

10. WARRANTY AND DISCLAIMER

Claims for compensation and any complaints regarding defects can only be asserted during the duration of the advertisement. GEWISTA does not guarantee that the objects provided with the advertisements in accordance with the order will be in operation and visible without interruption during the agreed upon term. GEWISTA shall not provide any compensation for any advertisements that may be damaged or not replaced in a timely manner. Temporary restrictions or disruptions of any kind and for any reason whatsoever shall not affect the order and shall not entitle the client to demand a refund or any other compensation. Liability for non-performance, interruption, premature termination, delay, defective performance, or other disruption of the advertising placement for reasons for which GEWISTA is not responsible or which are beyond GEWISTA's control, in particular due to force majeure (e.g., riots, sovereign interventions or requirements, construction and demolition measures carried out or abandoned by public authorities, institutions, power failures, IT failures, strikes, operational disruptions, weather conditions, damage or other impairments to the advertising space by third parties) is excluded. Compensation for consequential damages is excluded, except in cases of intentional or grossly negligent misconduct on the part of GEWISTA. This applies in particular to the production costs of advertising materials. Liability for a specific advertising result is excluded. Claims for damages arising from postponements or the cancellation of a display for the reasons stated in point 5 are excluded.

Special features for DW: The client must immediately notify DW in writing (e-mail) of any defects, in particular those resulting from the loss of advertising material (e.g., theft, construction work). Any warranty claims are excluded until notification has been received. The client has no claims based on defects that occurred more than three months prior. Warranty rights are also excluded insofar as they are based on a seasonal or temporary impairment of the advertising measures due to renovations or comparable actions by third parties. Assembly work (installation and removal) on objects belonging to GEWISTA and its partner companies must be carried out without exception by agents of GEWISTA. For all other installations not carried out by GEWISTA and its agents, the client shall be liable for any damage caused by the advertising object. If a film or board is in damaged condition (e.g., due to vandalism), GEWISTA shall be entitled, at its own discretion, to dismantle it at any time. GEWISTA shall inform the client of this immediately and restore the panel to its proper condition after print data has been transmitted. The client shall bear the costs for the maintenance and restoration of the objects (e.g., replacement due to theft, construction work, vandalism, damage, manipulation by third parties, etc.). The board remains the property of GEWISTA in all cases (this applies in particular to boards on masts/stands). After the order has expired, the objects must be restored to their original condition. The costs incurred shall be borne by the client.

Special features for DM: The client acknowledges that GEWISTA can only display the content as it is delivered. In the event of a malfunction, a failure, or a cyberattack on project partners and data sources that deliver content

to GEWISTA, GEWISTA accepts no liability for the content displayed. In such cases, GEWISTA will work with the project partners to restore the correct content as quickly as possible.

11. INTERRUPTION OF CAMPAIGNS

GEWISTA is entitled to interrupt the client's ongoing campaigns, particularly in the areas of DM and MW, at any time for the duration of a disaster warning message to be published at the request of the City of Vienna or a federal or state authority (e.g., display of a warning and an all-clear message). The client cannot derive any claims from such interruptions. GEWISTA also reserves the right to interrupt long-term DW campaigns at its own discretion if the booked placement is temporarily required for another campaign. In this case, the fee payable to GEWISTA shall be reduced proportionally by the amount corresponding to the period of interruption.

12. HANDLING OF TIME-LIMITED CONTENT

GEWISTA shall endeavor to install campaigns with time-limited content (e.g., time-limited promotions or prices, time-limited licensed images) after sufficient notification by the client in accordance with its capacities, or to remove such content otherwise. The installation /removal cannot be guaranteed completely and immediately, but will take place in the event of specific notification until the next posting.

13. RESPONSIBILITY FOR ADVERTISING CONTENT AND INDEMNIFICATION AND HOLDING HARMLESS

The client is solely responsible for the admissibility of the content of the advertising media. The client shall fully indemnify and hold GEWISTA harmless for any and all related claims by third parties, in particular claims for defamation, insult or damage to credit rating, violations of the Media Act, Copyright Act, data protection regulations, intellectual property and personal rights, and the Act Against Unfair Competition. This also applies to the content of web-based tools that GEWISTA integrates from third-party providers (e.g., social media, websites) as part of “innovative implementations.” GEWISTA has no control of this content and accepts no liability for it.

14. WITHDRAWAL BY GEWISTA

GEWISTA is entitled to withdraw from an order that has already been accepted, either in whole or in part, in the following cases:

- If, at the time of acceptance of the order, the form or content of the advertising material was unknown to GEWISTA and it is proven to be illegal; or
- GEWISTA has submitted the advertising material to the Advertising Council and the latter has objected to the advertising material within 48 hours of submission or has issued an informal recommendation not to display/play the advertising material; or
- In the event of elections (to the local council, state parliament, national parliament, etc.) or referendums or similar, insofar as this is necessary for election advertising.
- In the event of non-compliance with the terms of payment after setting a grace period of 3 days, in which case GEWISTA is entitled to remove or cover up advertising material immediately without further notice.
- If, due to cooperation with partner companies or public authorities, the advertising material is not approved by them.
- If the client has not delivered the advertising material by the agreed-upon delivery date. In the event of a justified withdrawal by GEWISTA in accordance with a) or b) before the start of installation/pasting, the cancellation conditions in point 18 shall apply accordingly mutatis mutandis. In the event of the client's withdrawal from the first day of the fourth week before the start of the term, the client shall pay the full fee. The client has the option of delivering replacement advertising material in accordance with the dates in the notice board calendar and the delivery dates. The client shall also pay the full fee if GEWISTA does not accept this replacement advertising material. In the event of a justified withdrawal by GEWISTA in accordance with c) and e), GEWISTA's claim to payment shall expire; the client shall not be entitled to derive any claims for damages from this. In the event of a justified withdrawal by GEWISTA in accordance with d), the client remains obliged to pay the full fee in accordance with point

14. In the event of a justified withdrawal by GEWISTA in accordance with f), the client remains obligated to pay the fee in accordance with point 7, second sentence, on a pro rata basis, up to and including the date of dispatch of GEWISTA's notice of withdrawal.

15. ADDITIONAL FEES AND REIMBURSEMENT OF COSTS

The client shall pay the following additional fees and reimburse the following costs:

- Fees for special services, e.g., blocking periods, packaging materials, customs duties, shipping costs, affixing stickers, posting outside the regular posting calendar, agreed upon returns of unused advertising materials.
- In the event of official confiscation of advertising materials: costs for their removal or covering.
- Legal transaction fees and advertising tax (if applicable).
- For collective posters (posters or commercials that advertise several products and brands or services of several companies), a surcharge of up to 200% may be charged.

16. RATES AND TERMS OF PAYMENT

The rates valid at the time of execution of the order according to the current price list determine the calculation of the fee. Rates are subject to change. All prices are exclusive of sales tax and any additional fees and charges in accordance with point 15, are payable promptly, net cash, without discount. Only payments made directly to GEWISTA will be accepted. GEWISTA reserves the right to demand 100% prepayment of the total order value for first-time orders from new customers, payable upon placing the order. GEWISTA is not obliged to grant an agent's commission, but decides on this on a case-by-case basis.

17. DELAYED PAYMENT

In the event of delayed payment or deferral, default interest of 9.2 percentage points above the base interest rate shall apply. In addition to the statutory interest, GEWISTA may also claim compensation for other damages incurred by it and caused by the client, in particular the necessary costs of appropriate extrajudicial collection or recovery measures, insofar as these are proportionate to the claim being pursued (Section 1333 (2) ABGB).

18. CANCELLATION TERMS AND CONDITIONS

The client may cancel orders, in whole or in part, in writing (e-mail). The cancellation fee shall be the following percentage of the gross order amount excluding advertising tax for the part of the order affected, whereby the deadline shall be calculated from the date of receipt by GEWISTA: Up to ten weeks before the start of the term 0%; up to eight weeks before, 10%; up to five weeks before, 30%; and, from the first day of the fourth week before the start of the term, 100%. Cancellation fees for order cancellations before the fourth week prior to the start date will be credited if the order is carried out within three months (but in the same calendar year as the initial order) on the same medium, subject to availability, to the same extent and under the agreed-upon conditions. Cancellation fees for order cancellations from the fourth week before the start date will not be credited. Cancellation must be made in writing (by post, fax, or email). The date of receipt of the notification by GEWISTA shall be deemed the date of timely receipt by GEWISTA. If the order is only booked within four weeks before the start date, cancellation free of charge is possible within 48 hours of booking. Cancellation of an order after this period will result in a cancellation fee of 100%. Production costs already incurred must be paid in full in all cases. The assignment or transfer of the client's business does not lead to premature termination of the contract with GEWISTA and has no influence on the client's payment obligation. In the case of DW and TM, any deviating cancellation conditions apply as stated in the order confirmation. If an order includes services provided by third parties, the cancellation conditions of these third parties shall apply to the relationship between GEWISTA and the client.

19. USE OF IMAGE AND DATA MATERIAL PROVIDED BY THE CLIENT

GEWISTA creates photos and films of its advertising media for the purposes of marketing communication and advertising for GEWISTA newsletters, social media channels, and press releases. The client agrees that in this context, the advertised subjects and all data material provided (e.g., subjects or spots) may be used for these purposes and warrants that such use does not infringe upon the rights of third parties, for which point 13 applies accordingly, mutatis mutandis.

Special features for DM: GEWISTA shall retain the client's advertising material for at least one year after termination of the contract, unless the law provides for a longer retention period. If the client has not requested return in writing by this time, GEWISTA shall be entitled to destroy or discard the material.

20. INTELLECTUAL PROPERTY RIGHTS OF GEWISTA

All rights to content produced and concepts created by GEWISTA remain the intellectual property of GEWISTA, unless the client has been expressly granted rights to them in writing. Any use of such content and concepts, in particular for advertising appearances in another medium, requires the prior written consent of GEWISTA.

21. THIRD-PARTY BUSINESS

Insofar as GEWISTA purchases advertising space from third-party companies, the contractual terms and conditions under which GEWISTA makes purchases from these third-party companies shall apply to the client, to whatever extent these differ or deviate from these General Terms and Conditions. GEWISTA shall refer to such differing or deviating terms and conditions separately in its offer.

22. DATA PROTECTION – COLLECTION OF ADVERTISING EXPENSES

GEWISTA is entitled to disclose the number of billboards displayed for the client, specifying the format and the gross contacts booked, to relevant offices or agencies that collect advertising expenditure data in all traditional media for the sole purpose of collecting advertising expenditure data. The customer acknowledges that, in connection with the business relationship between the client and GEWISTA, customer-specific data such as title, company/name, address, industry, etc., will be stored for the purposes of customer

records, sending information material, and invoicing. Information on the type and scope of data processing and the customer's rights in this context can be found in the data protection declaration at the www.gewista.at website.

23. SPECIAL CONDITIONS FOR THE TRANSPARENCY AND TARGETING OF POLITICAL ADVERTISING (as from 30 April 2026)

These Special Conditions are based on the European Commission's Implementing Regulation (EU) 2025/1410 of 9 July 2025 which specifies the format, model and technical specifications of the labels and transparency notices for political advertisements in accordance with Articles 11 and 12 of Regulation (EU) 2024/900. These Special Conditions for the transparency and targeting of political advertising are intended to comply with the requirements of Regulation (EU) 2024/900 of the European Parliament and of the Council of 13 March 2024 on the transparency and targeting of political advertising (hereinafter “**TPPA**”), in particular the labelling requirements and transparency notices. They apply to all offers, contracts, and services provided by GEWISTA Werbegeellschaft m.b.H. to its clients within its GEWISTA business division (hereinafter referred to as “**GEWISTA**”). These conditions constitute essential contractual obligations where political advertising is involved and, in the event of a breach, entitle GEWISTA to refuse the placement of advertisements and to terminate the relevant contracts for cause; GEWISTA expressly reserves the right to assert further claims.

1. The client shall inform GEWISTA whether and to what extent the advertising service forming the basis of this contract constitutes a political advertising service within the meaning of Section 3(5) of the TPPA and shall confirm that the criteria of Section 5(2) of the TPPA are met.

2. The Client shall ensure that the advertising content supplied by it complies with the labelling requirements under Article 11 of the TPPA and contains the necessary information, as well as providing references to further information (e.g. via a QR code or a website), where applicable using the template for visual labelling in accordance with EU Implementing Regulation 2025/1410.

3. The Client undertakes to comply with the requirements for transparency notices (Article 12 of the TPPA, obligation to publish transparency notices) and to make the necessary information available in the appropriate format, clearly indicating where this information can be accessed, where applicable using the template for transparency notices in accordance with EU Implementing Regulation 2025/1410.

4. GEWISTA points out that there is an obligation to report fees for political advertising services, which are to be attached as an annex to the annual report (Art. 14 TPPA). Where necessary, the client shall provide GEWISTA with the information required for this purpose.

5. GEWISTA notes that it has set up a contact channel through which reports of unlawful political advertising content can be submitted (Art. 15 TPPA). Furthermore, the Client shall provide a means for reporting potentially prohibited political content in accordance with Article 15(2) of the TPPA in its transparency notice (see point 3 above). Reference is also made to the further provisions of Article 15 of the TPPA. The parties shall inform each other in writing of any reports upon becoming aware of them.

6. The Client shall collect information to the extent specified in Article 9 of the TPPA and Article 12(4) of the TPPA and retain it for the period specified therein (currently seven years). The Client shall, upon request, provide GEWISTA with the relevant information immediately and free of charge, stating the reasons (e.g. a request from the competent authority).

7. The Client guarantees that its details are true and complete and shall also be liable for their accuracy. The Client shall indemnify GEWISTA against any claims by third parties, including the costs of legal defence. The Client undertakes to inform GEWISTA immediately as soon as it becomes aware, or there are indications, that its details or information within the meaning of the TPPA are wholly or partly untrue and/or incomplete. In such a case, the Client shall correct and/or complete the information without delay. If the Client engages a third party, the Client undertakes to impose the same obligations on that party, but remains responsible to GEWISTA and continues to be liable for the truthfulness and completeness of this information. GEWISTA shall be under no obligation to verify the accuracy of the information provided by the client in the transparency questionnaire, but reserves the right to possibly supplement or correct such information upon publication, for instance where the advertisement relates to a political process. In the event that the information provided by the client proves to be inaccurate and should GEWISTA suffer any loss or damage as a result, the client shall indemnify and hold GEWISTA harmless.

8. The Client shall grant GEWISTA access to the aforementioned information (e.g. to a website created by the Client for this purpose on which such information is made available) so that GEWISTA can verify whether the information is complete and accurate.

24. PLACE OF PERFORMANCE AND PLACE OF JURISDICTION

The place of performance is Vienna. The place of jurisdiction for all obligations of both parties is the court with jurisdiction in commercial matters and locally for Vienna, inner city, a.k.a., Innere Stadt.

As of: June 2, 2026